



Cutler-Hammer

SPX9000 FR10 – FR14 Adjustable Frequency Converters

Installation Manual

April 2006
Supersedes February 2004



April 2006

Important Notice — Please Read

The product discussed in this literature is subject to terms and conditions outlined in Eaton Electrical Inc. selling policies. The sole source governing the rights and remedies of any purchaser of this equipment is the relevant Eaton Electrical Inc. selling policy.

NO WARRANTIES, EXPRESS OR IMPLIED, INCLUDING WARRANTIES OF FITNESS FOR A PARTICULAR PURPOSE OR MERCHANTABILITY, OR WARRANTIES ARISING FROM COURSE OF DEALING OR USAGE OF TRADE, ARE MADE REGARDING THE INFORMATION, RECOMMENDATIONS AND DESCRIPTIONS CONTAINED HEREIN. In no event will Eaton Electrical Inc. be responsible to the purchaser or user in contract, in tort (including negligence), strict liability or otherwise for any special, indirect, incidental or consequential damage or loss whatsoever, including but not limited to damage or loss of use of equipment, plant or power system, cost of capital, loss of power, additional expenses in the use of existing power facilities, or claims against the purchaser or user by its customers resulting from the use of the information, recommendations and descriptions contained herein.

The information contained in this manual is subject to change without notice.

Cover Photo: Cutler-Hammer® SPX9000 FR10 Adjustable Frequency Converter

Table of Contents

SAFETY	v
Definitions and Symbols	v
Hazardous High Voltage	v
Warnings, Cautions and Notices	vi
CHAPTER 1 — GENERAL	1-1
CHAPTER 2 — REQUIREMENTS	2-1
Environmental Requirements	2-1
Cabinet	2-1
CHAPTER 3 — PRODUCT HANDLING	3-1
Product Type Designation Codes	3-1
Scope of Delivery	3-1
Receiving, Unpacking and Storing the Product	3-3
Lifting the Power Module	3-3
Lifting the AC Choke	3-4
CHAPTER 4 — INSTALLING AC CHOKES	4-1
Frames FR10 to FR12	4-1
Frames FR13 and FR14	4-2
CHAPTER 5 — INSTALLING POWER MODULE	5-1
Preparing the Enclosure	5-1
Mounting the Modules	5-4
Grounding the Power Modules	5-6
CHAPTER 6 — INTERNAL CONNECTIONS	6-1
Connecting Internal Power Cables, FR10 to FR12	6-1
Establishing Internal Busbar or Cable Connections, FR13 and FR14	6-2
CHAPTER 7 — INSTALLING CONTROL UNIT	7-1
Mounting the Control Unit	7-1
Connecting Power Supply and Internal Control Cables	7-3
CHAPTER 8 — PREPARING FOR EXTERNAL POWER CONNECTIONS	8-1
Installing Mounting Plate and Input Terminals, FR10 – FR12	8-1
Routing the Supply Busbars, FR13 and FR14	8-2
Installing Fuses	8-3
Installing EMC Grounding, FR10 to FR12	8-7
Installation of Ferrite Rings (Option) on the Motor Cable	8-8
Connecting Input and Output Power	8-8
CHAPTER 9 — ARRANGING AIR COOLING AND VENTILATION	9-1
Arranging Ventilation of the Enclosure	9-1
Steering the Internal Air Flow	9-2
Heat Dissipation	9-5
Temperatures Measured During Test Run	9-5
APPENDIX A — DIMENSIONAL DRAWINGS	A-1
Power Unit	A-1
AC Choke — CHK0650	A-6
AC Choke — CHK0520	A-7
AC Choke — CHK0400	A-8
AC Choke — CHK0261	A-9
Control Unit	A-10
APPENDIX B — WIRING DIAGRAMS	B-1
Optic Fiber Cables, Signal Listing and Connections	B-1
APPENDIX C — ADDITIONAL FUSE RECOMMENDATIONS	C-1

April 2006

List of Figures

Figure 3-1: Parts Included in the Delivery	3-1
Figure 3-2: Lifting the Power Module	3-3
Figure 3-3: Lifting the AC Choke	3-4
Figure 4-1: Installing AC Choke	4-1
Figure 4-2: Installing AC Choke (2 Chokes); FR13 and FR14	4-2
Figure 4-3: Installing AC Choke (3 Chokes); FR13 and FR14	4-2
Figure 5-1: Preparing the Enclosure for the Power Module	5-1
Figure 5-2: Preparing the Enclosure for the Modules	5-3
Figure 5-3: Mounting the Power Module, FR10	5-4
Figure 5-4: Mounting the Modules, FR13 and FR14	5-5
Figure 5-5: Grounding the Power Module, FR10 to FR12	5-6
Figure 5-6: Grounding the Modules, FR13/FR14	5-7
Figure 6-1: Connecting the Power Cables Between the AC Choke and the Power Unit	6-1
Figure 6-2: Placement of Busbars	6-3
Figure 6-3: Cabling from Choke to NFE (Front View)	6-3
Figure 6-4: Cabling from Choke to NFE (Side View)	6-4
Figure 7-1: FR10 – FR12 Control Unit Mounted on a Hinged Assembly Box (Optional)	7-2
Figure 7-2: FR13/FR14 Control Unit Mounted on a Hinged Assembly Box (Optional)	7-3
Figure 7-3: Connecting the Power Supply and Control Cables to the Control Unit, FR10 and FR11	7-4
Figure 7-4: View Behind the Protective Cover	7-5
Figure 7-5: Connecting the Power Supply and Control Cables to the Control Unit, FR12	7-6
Figure 7-6: Connecting the Power Supply and Control Cables, FR13	7-7
Figure 7-7: Connecting the Power Supply and Control Cables, FR14	7-8
Figure 7-8: Linking the Modules; See Figure in Table 2-4	7-9
Figure 7-9: Linking the Modules; See Figure in Table 2-5	7-10
Figure 7-10: Linking the Modules; See Figure in Table 2-6	7-10
Figure 7-11: Linking the Modules; See Figure in Table 2-7	7-11
Figure 7-12: Linking the Modules; See Figure in Table 2-8	7-11
Figure 8-1: Power Input Terminals	8-1
Figure 8-2: Route for Incoming Busbars Seen from the Front (Left) and Side (Right)	8-2
Figure 8-3: Installing Flush End Fuse; Busbar Connection Is Recommended (Right)	8-6
Figure 8-4: Installing EMC Grounding	8-7
Figure 8-5: Installation of Ferrite Rings	8-8
Figure 9-1: Ventilation Arrangements on the Cabinet (Examples)	9-1
Figure 9-2: Arrangements for Steering Hot Air to the Outlet at the Top of the Cabinet — One Cabinet Solution	9-3
Figure 9-3: Arrangements for Steering Hot Air to the Outlet at the Top of the Cabinet — Several Cabinet Solution	9-4
Figure 9-4: Roof Structure Seen from the Side	9-4
Figure A-1: SPX9000 Dimensions, FR10 Open Chassis	A-1
Figure A-2: SPX9000 Dimensions, FR11 Open Chassis	A-2
Figure A-3: SPX9000 Dimensions, FR13 Open Chassis Inverter	A-3
Figure A-4: SPX9000 Dimensions, FR13 Open Chassis Converter	A-4
Figure A-5: SPX9000 Dimensions, FR13 Open Chassis Converter — 900/1000 hp 480V	A-5
Figure A-6: AC Choke (CHK0650) Dimensions	A-6
Figure A-7: AC Choke (CHK0520) Dimensions	A-7
Figure A-8: AC Choke (CHK0400) Dimensions	A-8

List of Figures (Continued)

Figure A-9: AC Choke (CHK0261) Dimensions	A-9
Figure A-10: Control Unit Dimensions	A-10
Figure A-11: Control Unit with Star-Coupler Board, FR12 or FR14 Only	A-11
Figure B-1: Internal Fiber Cable Connections, FR10, FR11 and FR13	B-1
Figure B-2: Internal Fiber Cable Connections, FR12 and FR14	B-2

List of Tables

Table 1-1: SPX9000 FR10 – FR14 Adjustable Frequency Converters	1-1
Table 2-1: Cabinet Data for FR10	2-1
Table 2-2: Cabinet Data for FR11	2-1
Table 2-3: Cabinet Data for FR12	2-2
Table 2-4: Cabinet Data for SPX800 (480V) and SPX800 – H10 (575V)	2-2
Table 2-5: Cabinet Data for SPX900 – H10 (480V) (6-pulse)	2-3
Table 2-6: Cabinet Data for SPX900 – H10 (480V) (12-pulse)	2-3
Table 2-7: Cabinet Data for SPXH13 (575V) (6-pulse)	2-3
Table 2-8: Cabinet Data for SPXH12 – H16 (480V); SPXH13 (575V) (12-pulse); SPXH15 – H20 (575V)	2-4
Table 3-1: FR13 – FR14 Components	3-2
Table 5-1: FR10 to FR12 Mounting Dimensions in Inches (mm)	5-2
Table 5-2: FR13 and FR14 Mounting Dimensions in Inches (mm)	5-3
Table 6-1: Required Cable Sizes for the Internal Power Cables (90°C rating recommended)	6-2
Table 6-2: Recommended Busbar/Cable Sizes	6-2
Table 8-1: Copper Busbar Dimensions	8-1
Table 8-2: Copper Busbar Dimensions	8-2
Table 8-3: Bussman Fuse Recommendations, FR10 – FR12	8-3
Table 8-4: Fuse Recommendations, FR13 – FR14	8-5
Table 8-5: Tightening Torques for Flush and Fuses	8-6
Table 9-1: Minimum Ventilation Gaps	9-2
Table 9-2: Heat Dissipation from the AC Choke	9-5
Table 9-3: Temperatures Measured During an Accepted Test Run	9-5
Table A-1: Dimensions for SPX9000, FR10 Open Chassis	A-1
Table A-2: Dimensions for SPX9000, FR11 Open Chassis	A-2
Table A-3: Dimensions for SPX9000, FR13 Open Chassis Inverter	A-3
Table A-4: FR13 — Number of Input Units	A-4
Table A-5: Dimensions for SPX9000, FR13 Open Chassis Converter	A-4
Table A-6: FR13 — Number of Input Units	A-5
Table A-7: Dimensions for SPX9000, FR13 Open Chassis Converter — 900/1000 hp 480V	A-5
Table C-1: Ferraz Chawmut Fuse Recommendations	C-1

April 2006

Safety

Definitions and Symbols

 WARNING

This symbol indicates high voltage. It calls your attention to items or operations that could be dangerous to you and other persons operating this equipment. Read the message and follow the instructions carefully.



This symbol is the “Safety Alert Symbol.” It occurs with either of two signal words: CAUTION or WARNING, as described below.

 WARNING

Indicates a potentially hazardous situation which, if not avoided, can result in serious injury or death.

 CAUTION

Indicates a potentially hazardous situation which, if not avoided, can result in minor to moderate injury, or serious damage to the product. The situation described in the CAUTION may, if not avoided, lead to serious results. Important safety measures are described in CAUTION (as well as WARNING).

Hazardous High Voltage

 WARNING

Motor control equipment and electronic controllers are connected to hazardous line voltages. When servicing drives and electronic controllers, there may be exposed components with housings or protrusions at or above line potential. Extreme care should be taken to protect against shock.

Stand on an insulating pad and make it a habit to use only one hand when checking components. Always work with another person in case an emergency occurs. Disconnect power before checking controllers or performing maintenance. Be sure equipment is properly grounded. Wear safety glasses whenever working on electronic controllers or rotating machinery.

Warnings, Cautions and Notices

 CAUTION

Do not place the control unit close to the power cables. The power cables may disturb the data communications and cause false alarms.

 CAUTION

Be careful when connecting the fiber optic cables! Connecting the wires incorrectly will damage power electronic components.

 CAUTION

It is of utmost importance for the operation and lifetime of the adjustable frequency converter that the enclosure is well ventilated to keep the temperature below maximum allowed operating temperature. Repeated overheating will shorten the lifetime of the converter.

April 2006

Chapter 1 — General

This manual provides instructions for the installation of Cutler-Hammer® SPX9000 FR10 to FR14 Adjustable Frequency Converters from Eaton's electrical business in a cabinet, switchgear or any other enclosure.

FR10 and FR11 SPX9000 drives embody one power module and FR12 drives embody two power modules. FR13 drives are built of two to four non-regenerative front-end (NFE) units and one inverter unit. FR14 drives are built of two to four non-regenerative front-end (NFE) units and two inverter units. Parallel mounted chokes are also included.

SPX9000 modules are available as both 6-pulse (standard) and 12-pulse (optional) supply versions.

The manual applies to the SPX9000 FR10 to FR14 product series, which comprises the following adjustable frequency converters:

Table 1-1: SPX9000 FR10 – FR14 Adjustable Frequency Converters

Frame Size	Partial Catalog Number	I _H hp	I _L hp	Nominal Current (A)	Choke Type (6-pulse)	Choke Type (12-pulse)
480V (380 – 500V)						
10	SPX250	250	300	385	CHK0400	(2) CHK0261
	SPX300	300	—	460	CHK0520	(2) CHK0261
	SPX350	350	400	520	CHK0520	(2) CHK0261
11	SPX400	400	500	590	(2) CHK0400	(2) CHK0400
	SPX500	500	—	650	(2) CHK0400	(2) CHK0400
	SPX550	—	600	730	(2) CHK0400	(2) CHK0400
12	SPX600	600	—	820	(2) CHK0520	(2) CHK0520
	SPX650	—	700	920	(2) CHK0520	(2) CHK0520
	SPX700	700	800	1030	(2) CHK0520	(2) CHK0520
13	SPX800	800	900	1150	(2) CHK0650	(2) CHK0650
	SPX900	900	1000	1300	(3) CHK0520	(4) CHK0520
	SPXH10	1000	1200	1450	(3) CHK0520	(4) CHK0520
14	SPXH12	1200	1500	1770	(4) CHK0520	(4) CHK0520
	SPXH16	1600	1800	2150	(4) CHK0650	(4) CHK0650
575V (525 – 690V)						
10	SPX250	200	250	261	CHK0261	(2) CHK0261
	SPX300	250	300	325	CHK0400	(2) CHK0261
	SPX350	300	400	385	CHK0400	(2) CHK0261
11	SPX400	400	450	460	CHK0520	(2) CHK0400
	SPX450	450	500	502	CHK0520	(2) CHK0400
	SPX500	500	—	590	(2) CHK0400	(2) CHK0400
12	SPX550	—	600	650	(2) CHK0400	(2) CHK0400
	SPX600	600	700	750	(2) CHK0400	(2) CHK0400
	SPX700	700	800	820	(2) CHK0400	(2) CHK0400
13	SPX800	800	900	920	(2) CHK0520	(2) CHK0520
	SPX900	900	1000	1030	(2) CHK0520	(2) CHK0520
	SPXH10	1000	1250	1180	(2) CHK0650	(2) CHK0650
14	SPXH13	1350	1500	1500	(3) CHK0520	(4) CHK0520
	SPXH15	1500	2000	1900	(4) CHK0520	(4) CHK0520
	SPXH20	2000	2300	2250	(4) CHK0650	(4) CHK0650

The adjustable frequency converters can be installed in any enclosure that fulfills the requirements specified in **Chapter 2 — Requirements**. In the illustrations in this manual, Rittal TS8 is used as an example enclosure.

Installing the SPX9000 FR10 to FR14 adjustable frequency converters in an enclosure involves the following steps:

- Installing the AC Choke(s) (**Chapter 4**).
- Installing the Power Module(s) and Grounding (**Chapter 5**).
- Establishing the Internal Power Connections (**Chapter 6**).
- Installing the Control Unit (**Chapter 7**).
- Preparing for Input and Output Power Connections (**Chapter 8**).
- Arranging Air Cooling and Ventilation (**Chapter 9**).

General instructions for product handling are given in **Chapter 3 — Product Handling**. Dimensional drawings are found in **Appendix A — Dimensional Drawings**.

For more information about the products, refer to the user manuals.

Note: The installation of the adjustable frequency converters must be done by certified electricians. Safety regulations for electrical work must be followed during the installation work.

Note: Safe operation and full service lifetime of the product can be guaranteed only if the installation instructions in this manual are followed.

Note: The product warranty is not valid if the product is handled in a way that does not comply with the instructions in this manual and the user manual.

April 2006

Chapter 2 — Requirements

Environmental Requirements

Refer to the user manual for information on required operating temperature, humidity, etc. The user manual also states the free space required around the enclosure.

Note: EN 60439-1 specifies the ambient temperature for enclosed products as 95°F (35°C) (24h average)/104°F (40°C) (maximum). The ventilation and cooling of the room must be sufficient to keep the temperature below this level.

For information on the heat dissipation of the product and the required cooling air, refer to **Heat Dissipation** in **Chapter 9** and the user manual.

Cabinet

Cabinet Installation for FR10 to FR12

FR10 to FR12 SPX9000 IP00 power modules can be installed in cabinets. The cabinets have to meet the following requirements.

Table 2-1: Cabinet Data for FR10

Item	Specification
Width	Min. 23.6 Inches (600 mm)
Depth	Min. 23.6 Inches (600 mm) if the control unit is installed in front of the power unit, otherwise, min. 19.3 Inches (490 mm)
Height	Min. 70.9 Inches (1800 mm) if the AC choke is installed beneath the power unit, otherwise min. 59.1 Inches (1500 mm)
Mechanical Requirements	The cabinet must be able to support a total equipment weight of 606 lb. (275 kg) (if the power unit and the AC choke are installed in the same cabinet).
Protective Class	This manual applies to IP21/NEMA 1
Construction	According to EN 60439-1
Ventilation Openings	Refer to Arranging Ventilation of the Enclosure in Chapter 9

Table 2-2: Cabinet Data for FR11

Item	Specification
Width	Min. 31.5 Inches (800 mm)
Depth	Min. 23.6 Inches (600 mm) if the control unit is installed in front of the power unit, otherwise, min. 19.3 Inches (490 mm)
Height	Min. 70.9 Inches (1800 mm) if the AC choke is installed beneath the power unit, otherwise, min. 59.1 Inches (1500 mm)
Mechanical Requirements	The cabinet must be able to support a total equipment weight of 771 lb. (350 kg) (if the power unit and the AC choke are installed in the same cabinet).
Protective Class	This manual applies to IP21/NEMA 1
Construction	According to EN 60439-1
Ventilation Openings	Refer to Arranging Ventilation of the Enclosure in Chapter 9

Table 2-3: Cabinet Data for FR12

Item	Specification
Width	Min. 47.2 Inches (1200 mm)
Depth	Min. 23.6 Inches (600 mm) if the control unit is installed in front of the power unit, otherwise, min. 19.3 Inches (490 mm)
Height	Min. 70.9 Inches (1800 mm) if the AC choke is installed beneath the power unit, otherwise, min. 59.1 Inches (1500 mm)
Mechanical Requirements	The cabinet must be able to support a total equipment weight of 1211 lb. (550 kg) (if the power unit and the AC choke are installed in the same cabinet).
Protective Class	This manual applies to IP21/NEMA 1
Construction	According to EN 60439-1
Ventilation Openings	Refer to Arranging Ventilation of the Enclosure in Chapter 9

Cabinet Installation for FR13 to FR14

The power section of frames FR13 and FR14 comprise two to four non-generative front-end (NFE) units, AC chokes, inverter units and dU/dt-filters (required for FR14). Several cabinets are, therefore, needed. Example installations as well as cabinet requirements are presented below:

1 = NFE units 2 = AC chokes 3 = FI13 (inverter unit) 4 = dU/dt-filter

Table 2-4: Cabinet Data for SPX800 (480V) and SPX800 – H10 (575V)

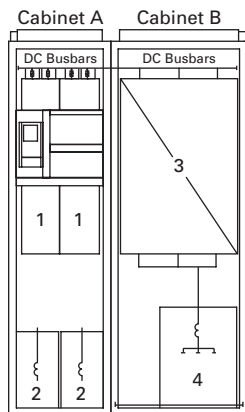

Item	Specification
Required Cabinet Width	Min. 23.6 Inches (600 mm) (Cabinet A) + 31.5 Inches (800 mm) (Cabinet B)
Required Cabinet Height	Min. 86.6 Inches (2200 mm)
Required Weight Carrying Capacity	SPX800 (480V): 1057 lb. (480 kg) (Cabinet A); 1189 lb. (540 kg) (Cabinet B) SPX800 (575V): 991 lb. (450 kg) (Cabinet A); 1189 lb. (540 kg) (Cabinet B) SPX900 (575V): 991 lb. (450 kg) (Cabinet A); 1189 lb. (540 kg) (Cabinet B) SPXH10 (575V): 1057 lb. (480 kg) (Cabinet A); 1189 lb. (540 kg) (Cabinet B)
Protection Class	This manual applies to IP21.
Construction	According to EN60439-1
Ventilation Openings	Refer to Arranging Ventilation of the Enclosure in Chapter 9

April 2006

Table 2-5: Cabinet Data for SPX900 – H10 (480V) (6-pulse)

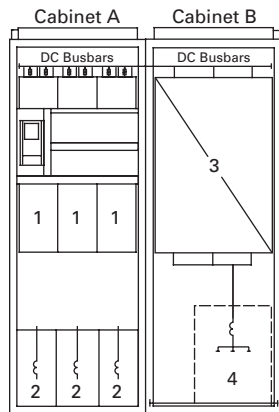

Item	Specification
Required Cabinet Width	Min. 31.5 Inches (800 mm) (Cabinet A) + 31.5 Inches (800 mm) (Cabinet B)
Required Cabinet Height	Min. 86.6 Inches (2200 mm)
Required Weight Carrying Capacity	1399 lb. (635 kg) (Cabinet A); 1300 lb. (590 kg) (Cabinet B)
Protection Class	This manual applies to IP21.
Construction	According to EN60439-1
Ventilation Openings	Refer to Arranging Ventilation of the Enclosure in Chapter 9

Table 2-6: Cabinet Data for SPX900 – H10 (480V) (12-pulse)

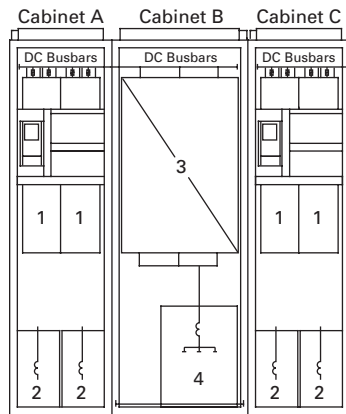

Item	Specification
Required Cabinet Width	Min. 23.6 Inches (600 mm) (Cabinet A) + 31.5 Inches (800 mm) (Cabinet B) + 23.6 Inches (600 mm) (Cabinet C)
Required Cabinet Height	Min. 86.6 Inches (2200 mm)
Required Weight Carrying Capacity	991 lb. (450 kg) (Cabinet A and C); 1189 lb. (540 kg) (Cabinet B)
Protection Class	This manual applies to IP21.
Construction	According to EN60439-1
Ventilation Openings	Refer to Arranging Ventilation of the Enclosure in Chapter 9

Table 2-7: Cabinet Data for SPXH13 (575V) (6-pulse)

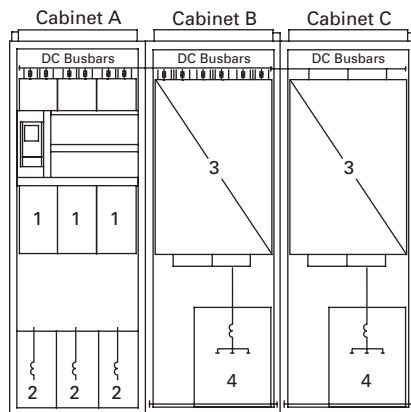

Item	Specification
Required Cabinet Width	Min. 31.5 Inches (800 mm) (Cabinet A) + 31.5 Inches (800 mm) (Cabinet B) + 31.5 Inches (800 mm) (Cabinet C)
Required Cabinet Height	Min. 86.6 Inches (2200 mm)
Required Weight Carrying Capacity	1399 lb. (635 kg) (Cabinet A); 1189 lb. (540 kg) (Cabinet B and C)
Protection Class	This manual applies to IP21.
Construction	According to EN60439-1
Ventilation Openings	Refer to Arranging Ventilation of the Enclosure in Chapter 9

Table 2-8: Cabinet Data for SPXH12 – H16 (480V); SPXH13 (575V) (12-pulse); SPXH15 – H20 (575V)

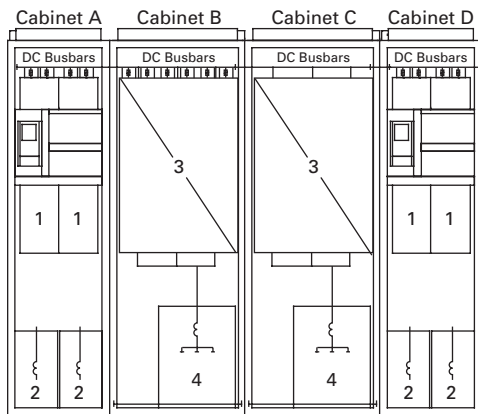

Item	Specification
Required Cabinet Width	Min. 23.6 Inches (600 mm) (Cabinet A and D) + 31.5 Inches (800 mm) (Cabinet B and C)
Required Cabinet Height	Min. 86.6 Inches (2200 mm)
Required Weight Carrying Capacity	SPXH13 (575V) (12-pulse): 991 lb. (450 kg) (Cabinet A and D); 1189 lb. (540 kg) (Cabinet B and C)
	SPXH12 (480V): 991 lb. (450 kg) (Cabinet A and D); 1189 lb. (540 kg) (Cabinet B and C)
	SPXH15 (575V): 991 lb. (450 kg) (Cabinet A and D); 1189 lb. (540 kg) (Cabinet B and C)
	SPXH16 (480V): 1057 lb. (480 kg) (Cabinet A and D); 1189 lb. (540 kg) (Cabinet B and C)
	SPXH20 (575V): 1057 lb. (480 kg) (Cabinet A and D); 1189 lb. (540 kg) (Cabinet B and C)
Protection Class	This manual applies to IP21.
Construction	According to EN60439-1
Ventilation Openings	Refer to Arranging Ventilation of the Enclosure in Chapter 9

April 2006

Chapter 3 — Product Handling

Product Type Designation Codes

Product type designation codes are found on the power module and the control unit. For an explanation of the type designation codes, refer to the user manual.

Scope of Delivery

FR10 to FR12

The delivery includes:

- Power module(s) with one integrated control unit (For FR12, this is referred to as Power Module 1 and the other one as Power Module 2.)
- AC choke(s) — See **Table 1-1**
- Control unit with fixing plate
- FR12 units only: optical cable set for internal control connections between control unit and power modules
- Installation manual
- User manual

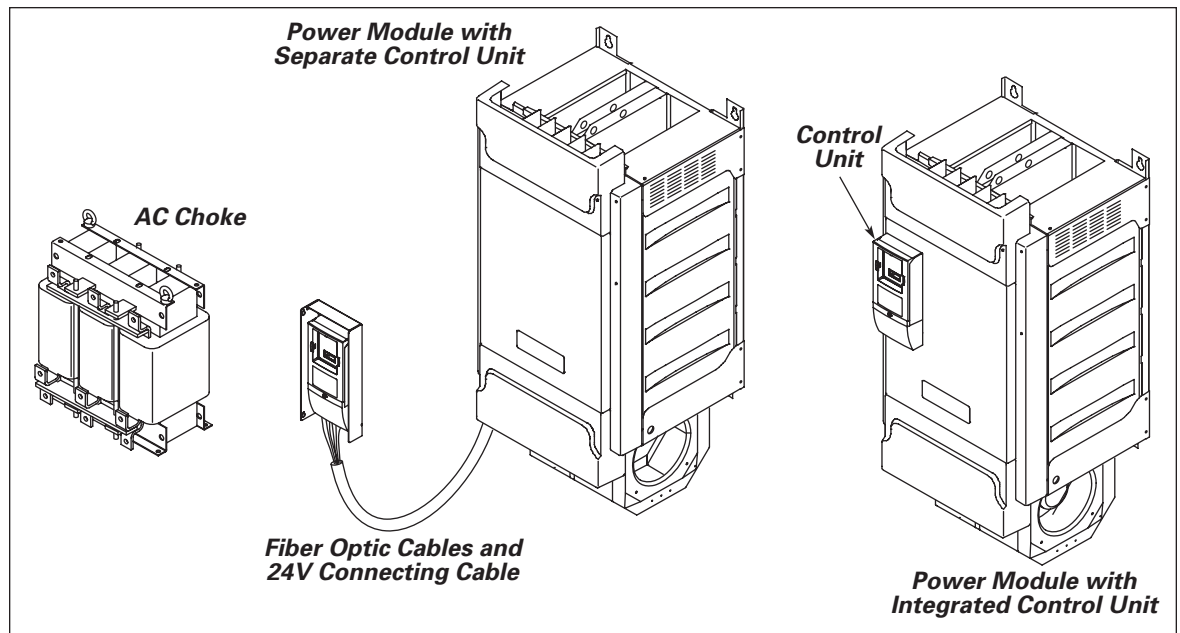

Figure 3-1: Parts Included in the Delivery

The following optional equipment is delivered on request:

- Door installation kit for installing the control panel on the enclosure door.
- Control unit with fixing plate. See also **Chapter 7**.
- Cable set, including seven optical cables and a 24V connecting cable, readily connected to the power module and the control unit. Standard length: 7.55 feet (2.3m)

FR13 and FR14

The standard delivery includes:

- 1 or 2 inverter modules
- 2 to 4 non-generative front-end (NFE) units with 2 or 3 modules mounted in brackets
- Control unit with fixing plate. See also **Chapter 7**.
- AC choke per each NFE unit — See **Table 1-1**
- FR14 only: dU/dt filter (optional; 1 per inverter module)
- Cable set for NFEs and inverter modules
- Optical cable set for internal control connections between control unit and power modules
- Installation manual
- User manual

Table 3-1: FR13 – FR14 Components

Frame Size	Partial Catalog Number	Supply	Inverter Unit(s)	NFE Units	Choke Type
480V (380 – 500V)					
13	SPX800 SPX900 SPXH10	6-pulse	(1) 1150A (1) 1300A (1) 1450A	(2) 650A (3) 650A (3) 650A	(2) CHK0650 (3) CHK0520 (3) CHK0520
14	SPXH12 SPXH16	6-pulse	(2) 1150A (2) 1150A	(4) 650A (4) 650A	(4) CHK0520 (4) CHK0650
13	SPX800 SPX900 SPXH10	12-pulse	(1) 1150A (1) 1300A (1) 1450A	(2) 650A (4) 650A (4) 650A	(2) CHK0650 (4) CHK0520 (4) CHK0520
14	SPXH12 SPXH16	12-pulse	(2) 1150A (2) 1150A	(4) 650A (4) 650A	(4) CHK0520 (4) CHK0650
575V (525 – 690V)					
13	SPX800 SPX900 SPXH10	6-pulse	(1) 920A (1) 1030A (1) 1180A	(2) 650A (2) 650A (2) 650A	(2) CHK0520 (2) CHK0520 (2) CHK0650
14	SPXH13 SPXH15 SPXH20	6-pulse	(2) 920A (2) 920A (2) 1180A	(3) 650A (4) 650A (4) 650A	(3) CHK0520 (4) CHK0520 (4) CHK0650
13	SPX800 SPX900 SPXH10	12-pulse	(1) 920A (1) 1030A (1) 1180A	(2) 650A (2) 650A (2) 650A	(2) CHK0520 (2) CHK0520 (2) CHK0650
14	SPXH13 SPXH15 SPXH20	12-pulse	(2) 920A (2) 920A (2) 1180A	(4) 650A (4) 650A (4) 650A	(4) CHK0520 (4) CHK0520 (4) CHK0650

The following optional equipment is delivered on request:

- Door installation kit for installing the control panel on the enclosure door.
- Cable set, including seven optical cables and a 24V connecting cable, readily connected to the power module and the control unit. Standard length: 7.55 feet (2.3m)

April 2006

Receiving, Unpacking and Storing the Product

The product is delivered packed in a plywood case, which can be recycled or destroyed by burning. Instructions for receiving, handling and storing the product, as well as general warranty terms can be found in the user manual.

Lifting the Power Module

The power module can be lifted by the holes on top of the module. Fasten the module symmetrically in at least two holes. The lifting equipment must be able to carry the weight of the power module. For FR10 to FR12, see **Figure 3-2**. For FR13 and FR14, see **Chapter 2, Cabinet Installation for FR13 to FR14**.

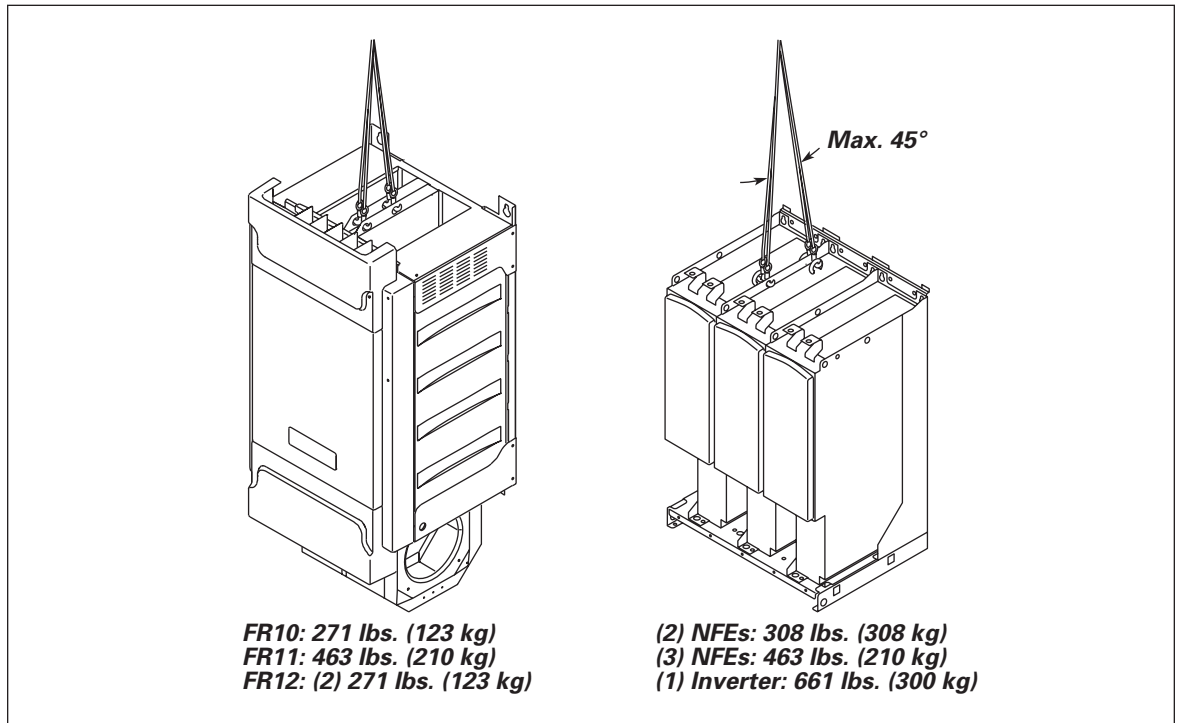

Figure 3-2: Lifting the Power Module

Note: The module can temporarily rest on the cooling fan assembly, but shocks or non-vertical forces may cause damage to the cooling fans.

Lifting the AC Choke

The AC choke can be lifted by the two eyebolts on top of the unit. The weight of the AC choke depends on the type (see **Figure 3-3**).

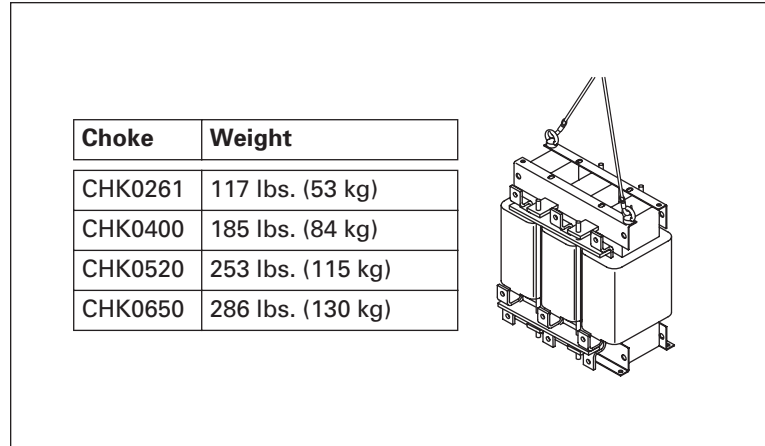

Figure 3-3: Lifting the AC Choke

April 2006

Chapter 4 — Installing AC Chokes

Frames FR10 to FR12

The recommended location for the AC choke is the bottom part of the enclosure, where it should be installed close to the rear wall. For a possible later installation of a fuse switch, it may be practical to install the AC choke somewhat to the left.

Fasten the choke on an assembly plate or use mounting rails.

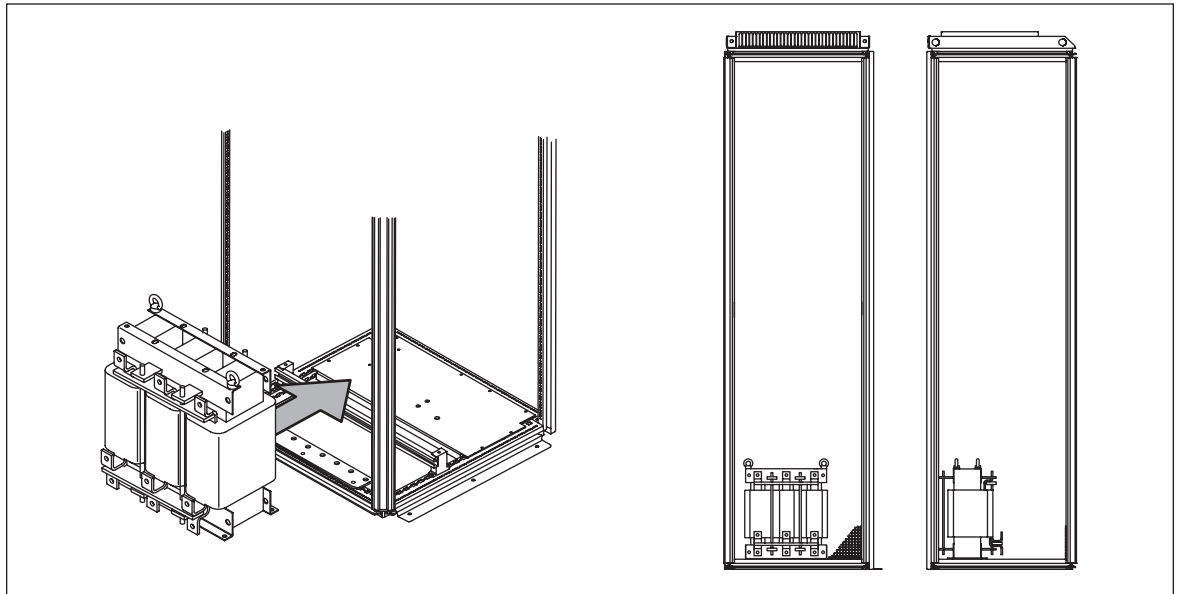

Figure 4-1: Installing AC Choke

Note: An upper support plate must be installed above the choke if the cabinet is transported in horizontal position. A possible fixed support plate must be equipped with air circulation holes. See **Figure 9-2** on **Page 9-3**.

Frames FR13 and FR14

Check the needed amount and type of chokes e.g. in **Table 1-1**. Place the chokes on the bottom of the enclosure as shown in **Figure 4-2**.

Fasten the choke on an assembly plate or use mounting rails.

Note: An upper support plate must be installed above the choke if the cabinet is transported in horizontal position. The support plate must be equipped with air circulation holes. See **Figure 9-2** on **Page 9-3**.

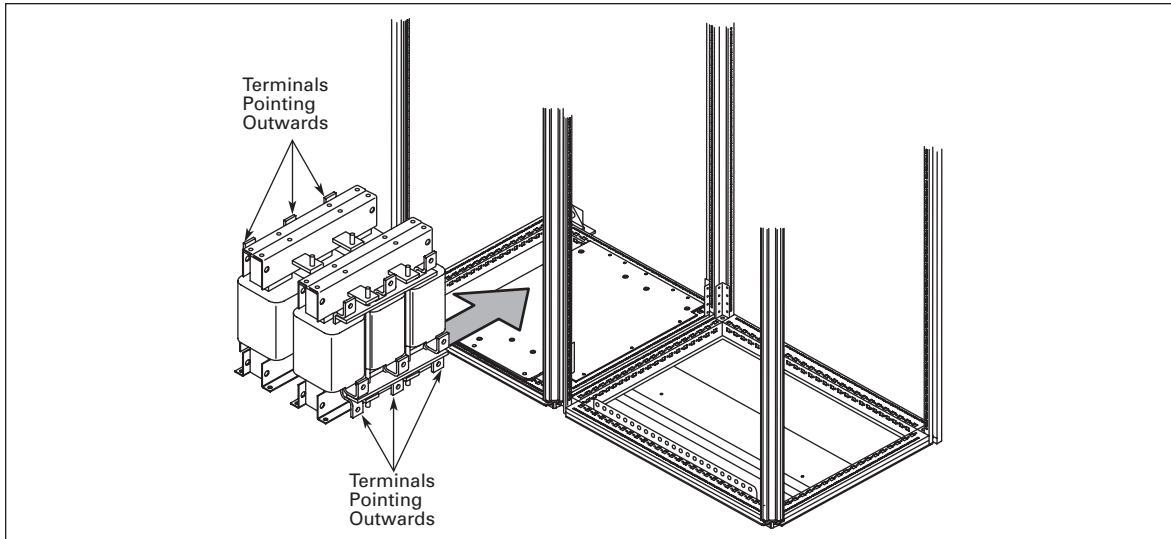

Figure 4-2: Installing AC Choke (2 Chokes); FR13 and FR14

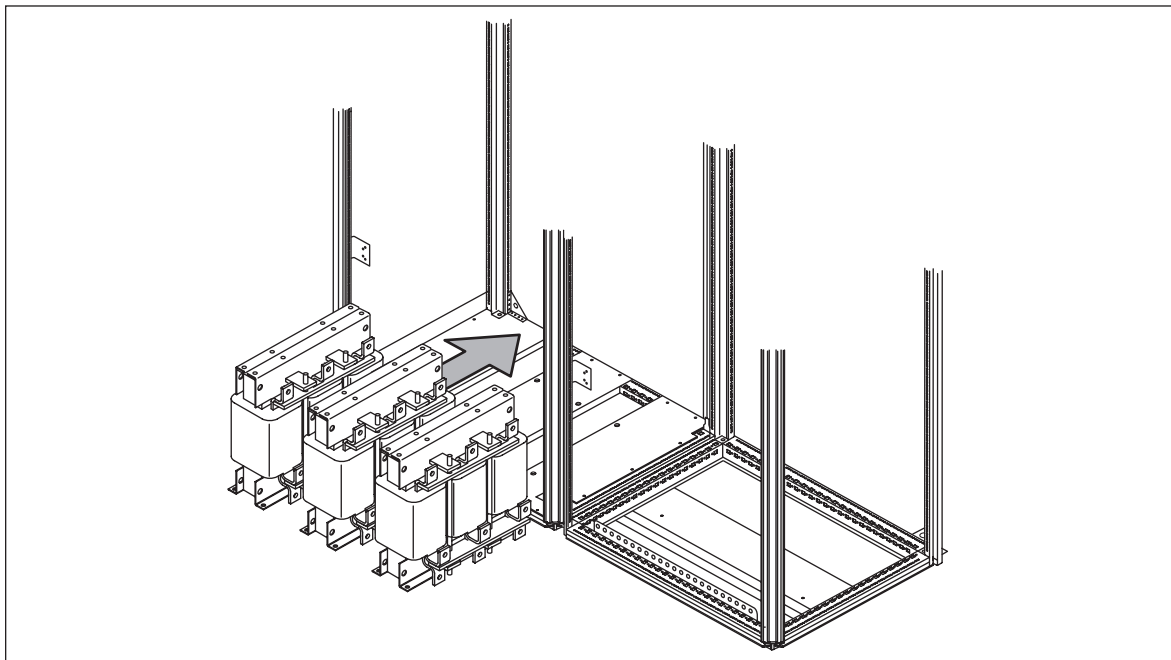

Figure 4-3: Installing AC Choke (3 Chokes); FR13 and FR14

April 2006

Chapter 5 — Installing Power Module

Preparing the Enclosure

To facilitate a possible future replacement of boards as well as other service work, it is recommended that the power module be mounted on rails.

Mounting Dimensions for FR10 to FR12

Fasten mounting rails to the sides of the cabinet at distances given under F (from the top) and G (from the bottom) in **Table 5-1**. Leave a space (A) between the module and the walls on both sides for the internal cooling air circulation.

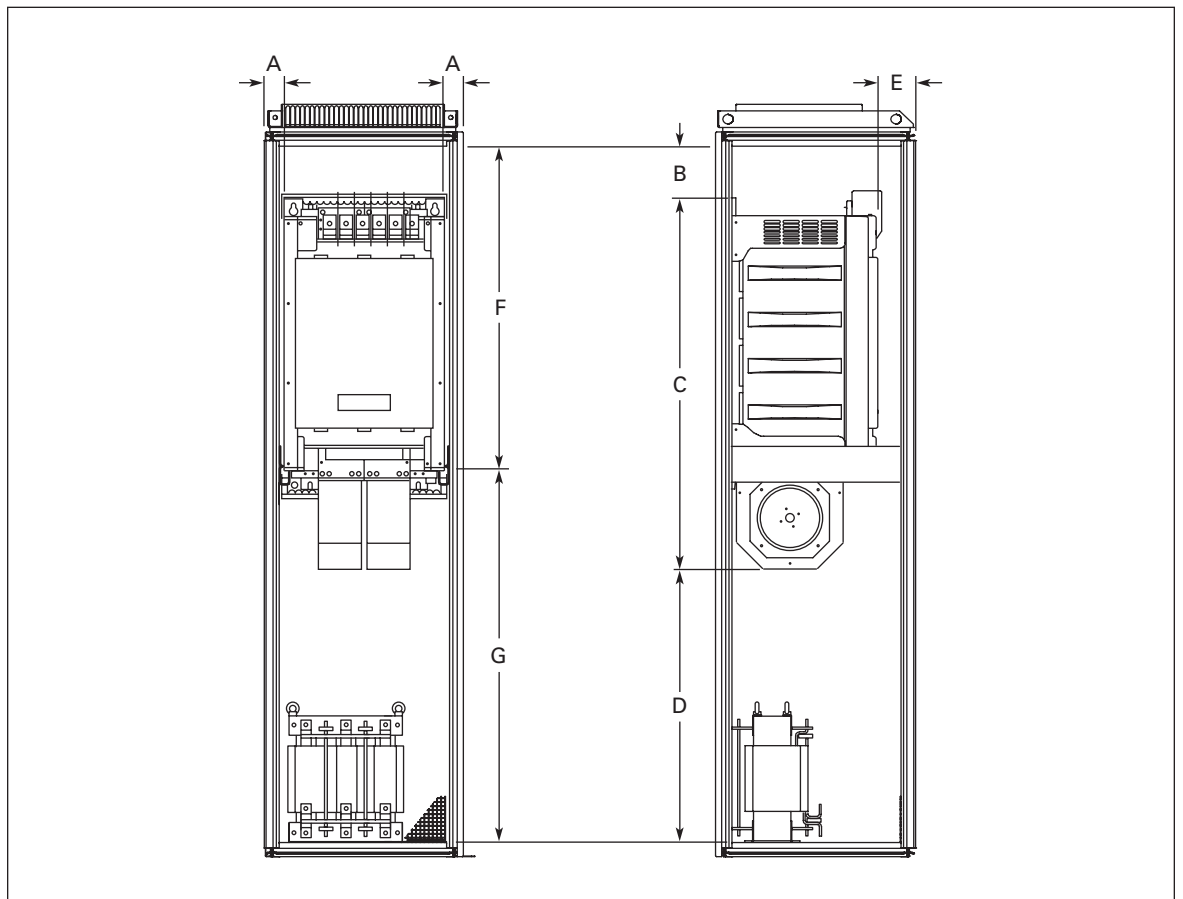

Figure 5-1: Preparing the Enclosure for the Power Module

The power module should be fastened to the rear side of the enclosure as shown in **Figure 5-3**. For this purpose, install two mounting bars on the rear wall of the cabinet at appropriate levels.

Note the following dimensions that are essential for placing the power module.

Table 5-1: FR10 to FR12 Mounting Dimensions in Inches (mm)

A	B	C	D	E	F	G
1.97 (50) ^①	3.94 (100)	44.09 (1120)	21.65/11.42 (550/290)	4.57/1.73 (116/44)	36.14 (918)	33.46/23.23 (850/590)

A = Minimum distance to the side walls or adjacent components.

^① Note that the two cabinets, in which the modules of frame FR12 are installed, require no clearance between them.

B = Minimum distance from the top of the cabinet; this space is needed for the power cables (see **Figure 6-1**).

C = Module height.

D = Minimum distance from the bottom of the enclosure if the AC choke is installed at the bottom of the enclosure. If the choke is installed in another location, the distance must not, however, be smaller than the second number.

E = Minimum distance from the cabinet door; this is to enable the control unit to be installed in front of the power module. The second number designates the minimum distance from the door if the control unit is installed in any other location.

F = Minimum distance from the mounting rails to top of the cabinet.

G = Minimum distance from the mounting rails to the bottom of the cabinet. If the choke is installed in another location, the distance must not, however, be smaller than the second number.

Also see the dimensional drawings in **Appendix A**.

April 2006

Mounting Dimensions for FR13 and FR14

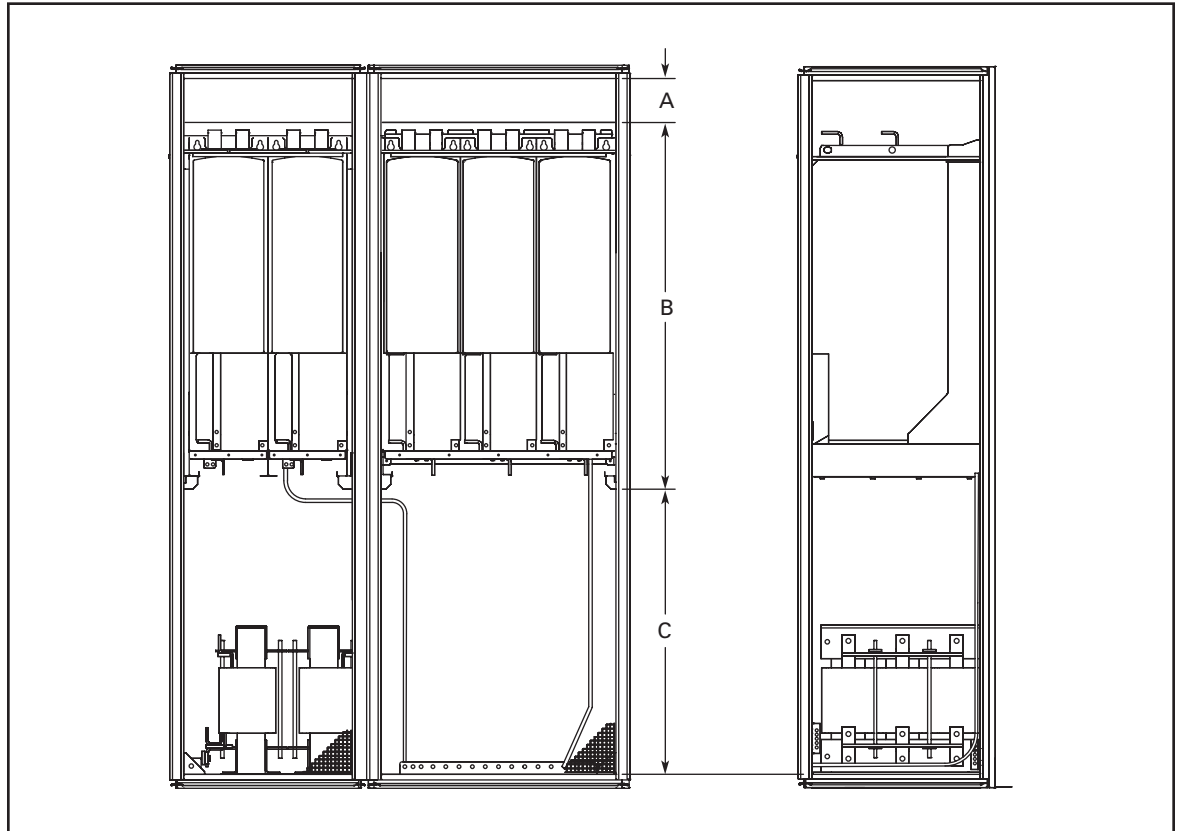

Figure 5-2: Preparing the Enclosure for the Modules

Note the following dimensions that are essential for placing the modules.

Table 5-2: FR13 and FR14 Mounting Dimensions in Inches (mm)

A	B	C
6.89 (175)	41.34 (1050)	23.62/11.82 (600/300)

A = Minimum distance from the top of the cabinet; this space is needed for the fuses and busbars.

B = Module height.

C = Minimum distance from the bottom of the enclosure if the AC choke is installed at the bottom of the enclosure. If the choke is installed in another location, the distance must not, however, be smaller than the second number.

Also see the dimensional drawings in **Appendix A**.

Mounting the Modules

Mounting the Power Modules for FR10 to FR12

Note: If the space around the power module is narrow, lead the internal power cables along the wall and fasten them in brackets before mounting the power module. See **Chapter 6**.

Fasten the power module to the rear wall of the enclosure utilizing the mounting holes in the frame.

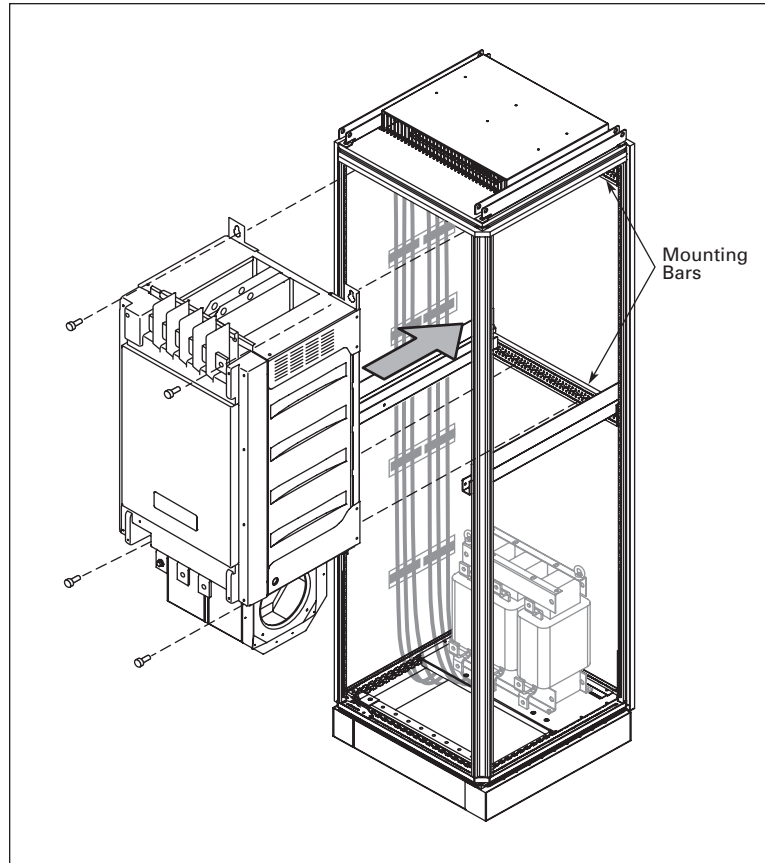

Figure 5-3: Mounting the Power Module, FR10

Note: If the power module is installed before the AC choke, the center of gravity is very high at this stage. Support the enclosure thoroughly during the assembly.

April 2006

Mounting the Modules for FR13 and FR14

Fasten the power module to the rear wall of the enclosure utilizing the mounting holes in the frame.

The modules should be fastened to the rear side of the enclosure as shown in **Figure 5-4**. For this purpose, install a mounting bar on the rear wall of the cabinet at appropriate level. Two module supports shall also be mounted on the sides. The modules are intended to rest on these supports.

Note: Support the enclosure thoroughly during the assembly.

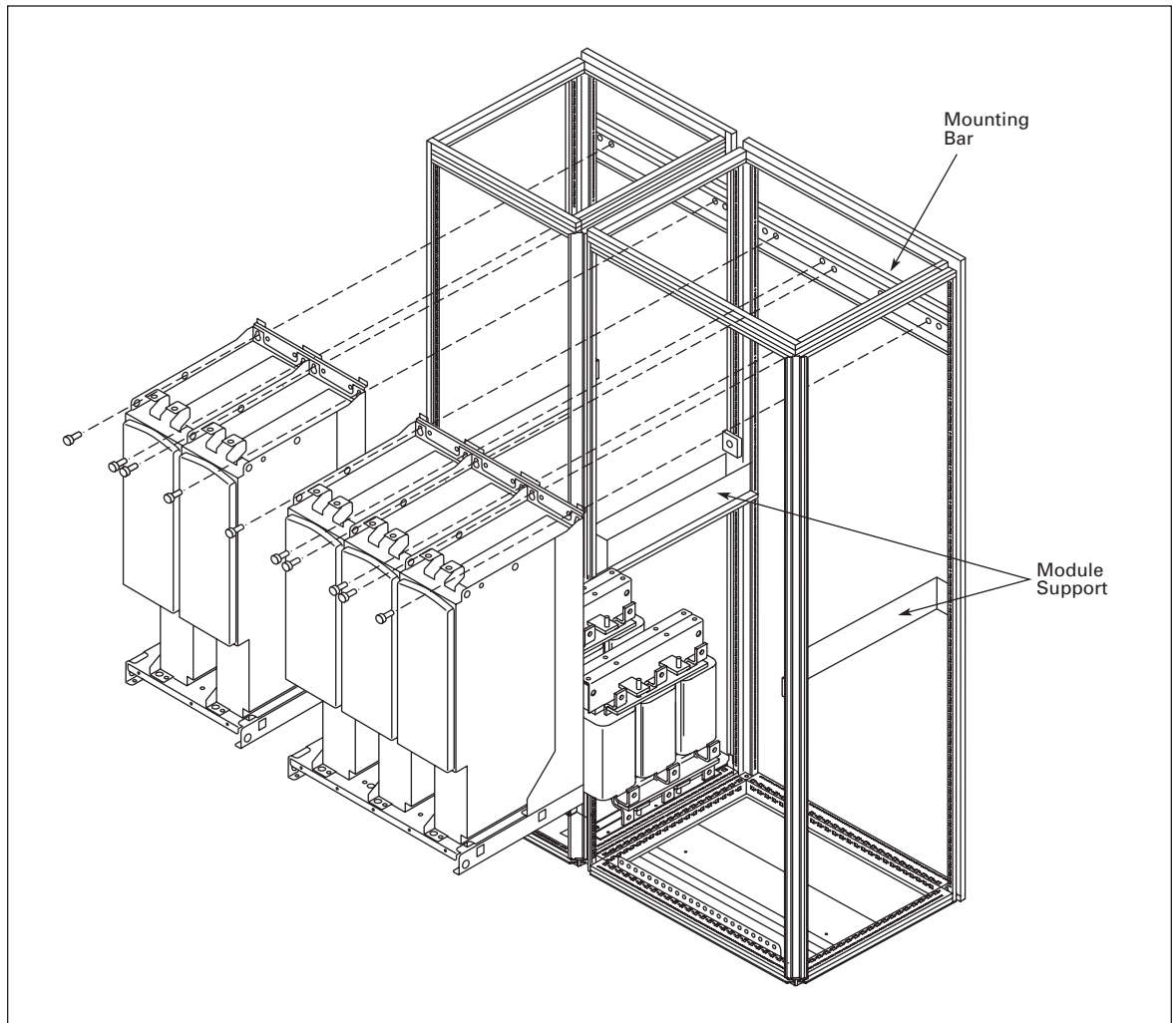

Figure 5-4: Mounting the Modules, FR13 and FR14

Grounding the Power Modules

Install a PE rail, for instance, at the bottom front of the enclosure. See **Figures 5-5** and **5-6** below.

Frames FR10 to FR12: Connect a grounding cable from the grounding connector at the lower right hand side of the power module frame to the PE rail of the enclosure.

Frames FR13 and FR14: Route a grounding cable from the grounding connector of the NFE unit and the inverter unit through the cabinet wall to the PE rail of the cabinet with the inverter module.

Use a copper grounding cable with a cross-sectional area of at least $2 \times 35 \text{ mm}^2$ per power module, according to local regulations for grounding cables. See **Figure 5-5**.

Note: The PE rail must be connected to external ground at the installation site according to local regulations.

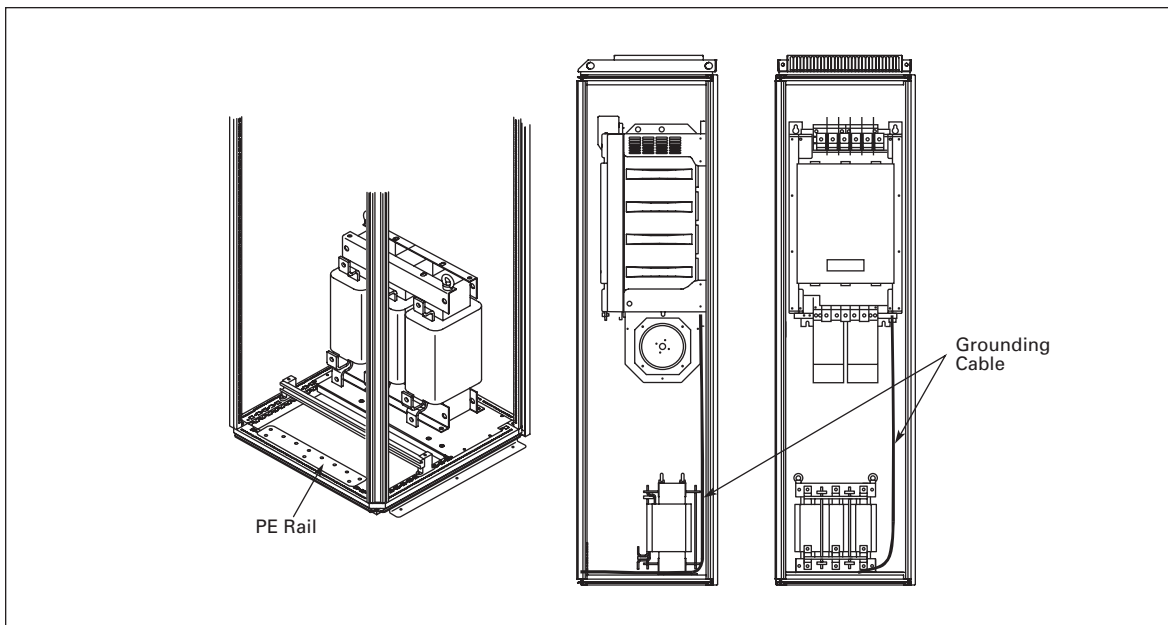

Figure 5-5: Grounding the Power Module, FR10 to FR12

April 2006

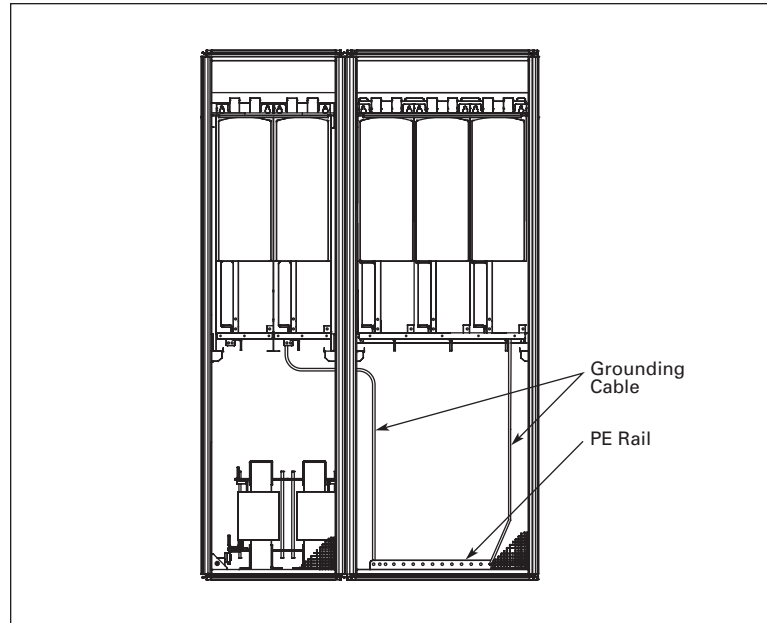

Figure 5-6: Grounding the Modules, FR13/FR14

April 2006

Chapter 6 — Internal Connections

Connecting Internal Power Cables, FR10 to FR12

Connect three power cables according to **Figure 6-1** to the output terminals of the AC choke and the input terminals of the power module. It is recommended to use cables designed for 90°C. Connect the L1 cable from the L1 terminal of the AC choke to the L1 input terminal of the power module, the L2 cable to the L2 terminal, and the L3 cable to the L3 terminal.

Note: The choke has two sets of output terminals designed for different voltages/frequencies. Use the upper set for 500V/50 Hz, 525V/50 Hz, 600V/60 Hz, and 690V/50 Hz and the lower set for 400V/50 Hz and 480V/60 Hz.

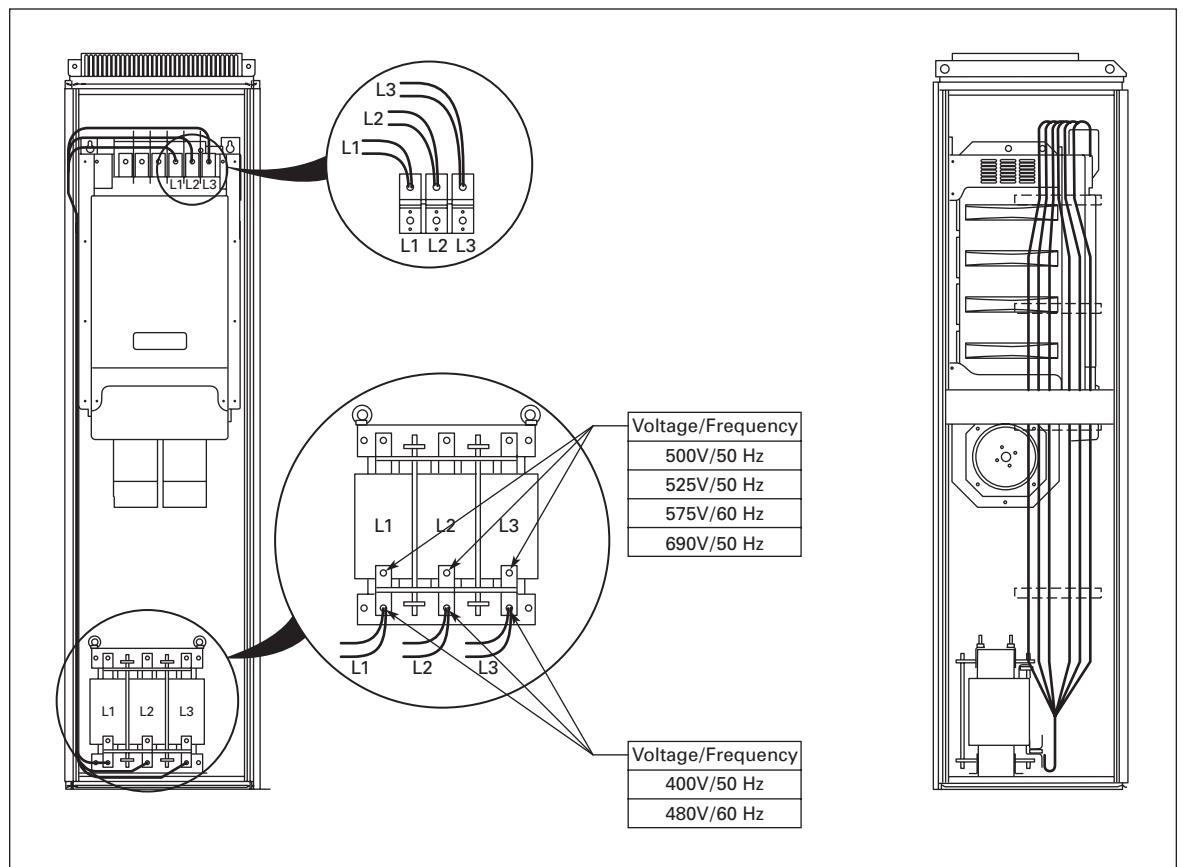

Figure 6-1: Connecting the Power Cables Between the AC Choke and the Power Unit

**Table 6-1: Required Cable Sizes for the Internal Power Cables
(90°C rating recommended)**

Product	Temperature Rating	Cu Cables	
		Cable Size, mm ² per Phase	Specification
SPX200_5	90°C	2 x 70	GENELEC HD 21.7 H07V2-K
SPX250_5 SPX250_4, SPX300_5	70°C	2 x 95	Standard
SPX300_4, SPX400_5	90°C	2 x 95	GENELEC HD 21.7 H07V2-K
SPX450_5 SPX350_4	70°C	2 x 120	Standard
SPX400_4, SPX500_5	90°C	2 x 2 x 70	GENELEC HD 21.7 H07V2-K
SPX500_4, SPX550_5 SPX550_4 SPX600_5 SPX700_5	70°C	2 x 2 x 95	Standard
SPX600_4	90°C	2 x 2 x 95	GENELEC HD 21.7 H07V2-K
SPX650_4 SPX700_4	70°C	2 x 2 x 120	Standard

Establishing Internal Busbar or Cable Connections, FR13 and FR14

The electrical power connections between the NFE units and the inverter module are made using busbars. However, the internal connections from the AC choke to the NFE unit can also be established using copper cable. See figures below for the correct placement of the busbars/cables and **Table 6-2** for the recommended sizes.

Table 6-2: Recommended Busbar/Cable Sizes

Product	Busbar Size NFE – INU (mm)	Busbar Size/Phase ① (Choke — NFE) (mm)	Cable Size/Phase (Choke — NFE) (mm ²)	Remarks
Supply Voltage 380 – 500V				
SPX800	60 x 10	40 x 6	2 x 150	
SPX900 SPXH10	80 x 10	40 x 6	2 x 120	
SPXH12 SPXH16	60 x 10	40 x 6	2 x 120 2 x 150	Routing: Use symmetrical construction. See pictures on Page 2-2 .
Supply Voltage 525 – 690V				
SPX800 SPX900 SPXH10	60 x 10	40 x 6	2 x 120 2 x 150	
SPXH13	80 x 10	40 x 6	2 x 120	
SPXH15 SPXH20	60 x 10	40 x 6	2 x 120 2 x 150	Routing: Use symmetrical construction. See pictures on Page 2-2 .

① Rigid copper connection.

April 2006

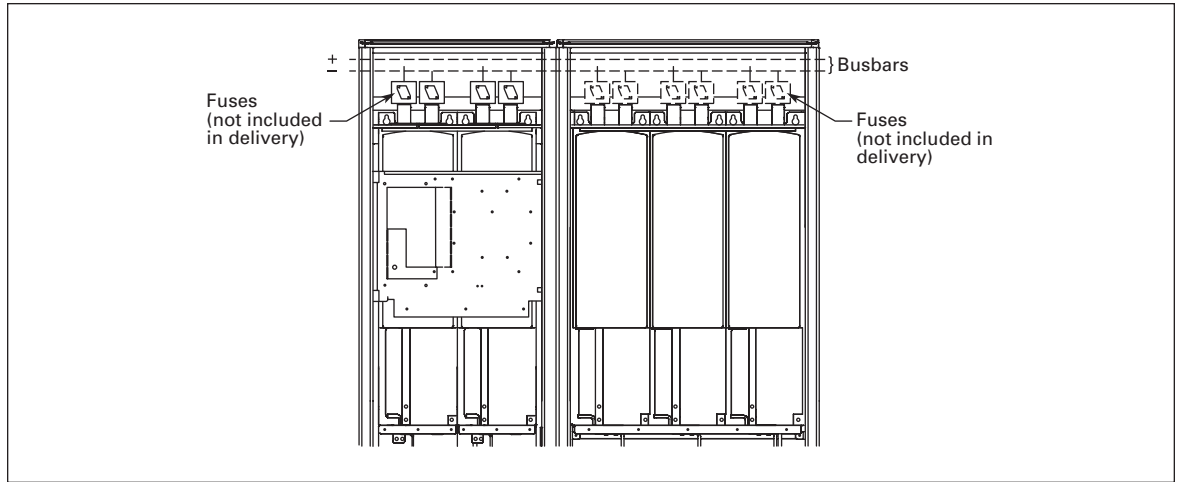

Figure 6-2: Placement of Busbars

Note: Busbar alignment should be vertical in order to allow the maximum flow of cooling air.

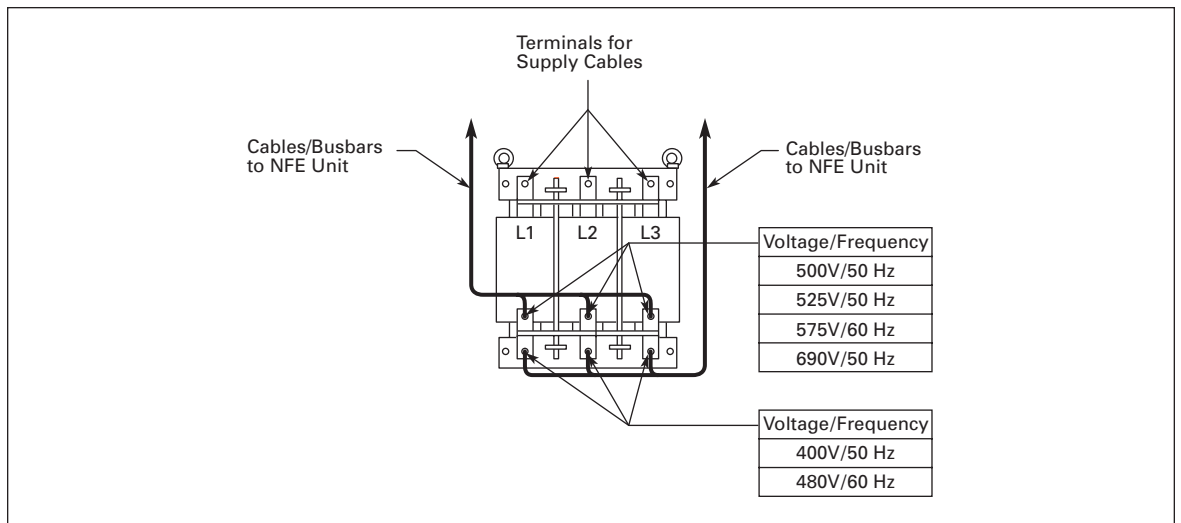

Figure 6-3: Cabling from Choke to NFE (Front View)

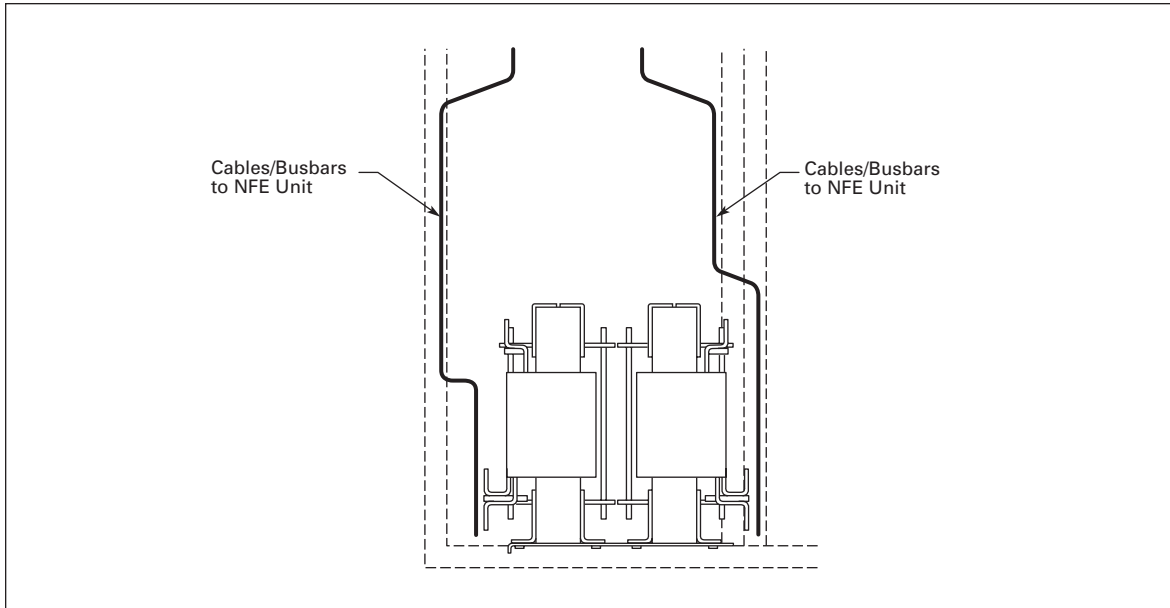

Figure 6-4: Cabling from Choke to NFE (Side View)

April 2006

Chapter 7 — Installing Control Unit

Note: The SPX9000 FR10 to FR12 drive can be delivered with the control unit integrated with power module or separated from power module and fixed to a mounting plate that can be installed on the enclosure. If your control unit was ordered separated from the power module, see **Mounting the Control Unit** below.

The SPX9000 FR13/FR14 drive is always delivered with the control unit separated from the power module. See **Mounting the Control Unit** below and, for dimensions of the control unit, see **Appendix A**.

Mounting the Control Unit

Note: Before mounting the control unit, connect the 24V connecting cable and the fiber optic cables to the power unit module as described in **Connecting Power Supply and Internal Control Cables**.

Fasten the mounting plate to a sidewall or to the frame of the enclosure. The standard length of the connecting cable and the fiber optic cables is 4 ft. (1.2m), which means that the control unit must be placed within this distance from the power unit. Note the minimum bending radius of the fiber optic cables on **Page 7-5**.

CAUTION

Do not place the control unit close to the power cables. The power cables may disturb the data communications and cause false alarms.

To ensure a proper grounding of the control unit assembly, Eaton engineers recommend that an additional grounding cable be drawn from the mounting plate and connected to the cabinet frame. Use a braided copper cable designed for high-frequency signals.

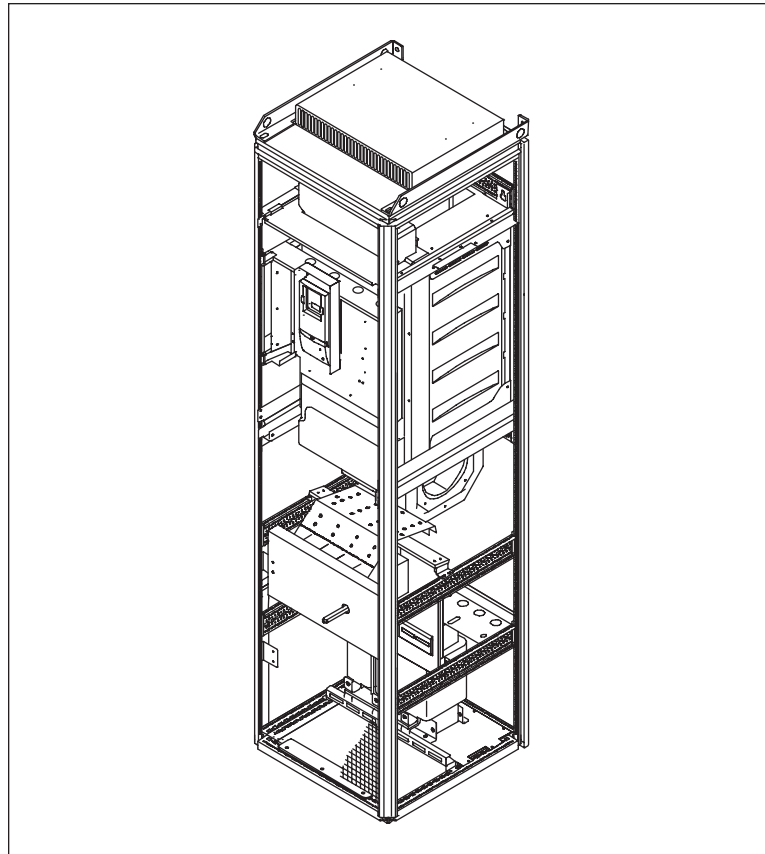

Figure 7-1: FR10 – FR12 Control Unit Mounted on a Hinged Assembly Box (Optional)

April 2006

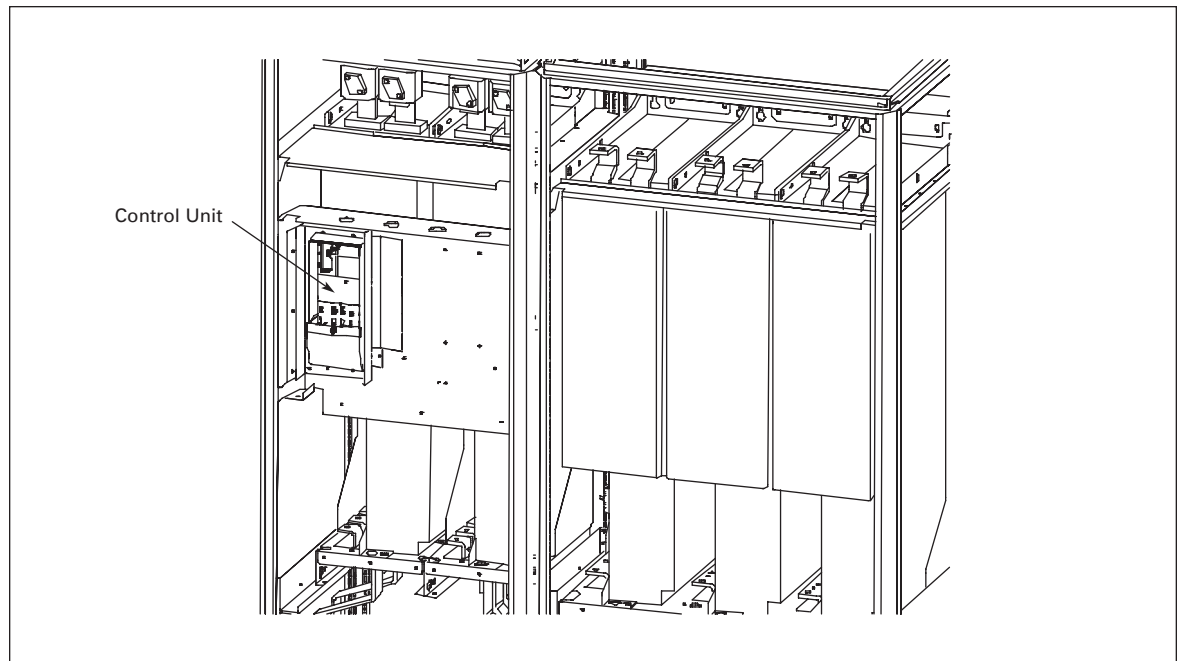

Figure 7-2: FR13/FR14 Control Unit Mounted on a Hinged Assembly Box (Optional)

Connecting Power Supply and Internal Control Cables

Note: The drive option with the integrated control unit does not require connecting of cables by the customer except for frame FR12.

Frames FR10 and FR11

The control unit uses 24V DC supplied from the ASIC board (ASIC = Application Specific Integrated Circuit) which is shown in **Figures 7-3** and **7-4**. To access the board, remove the protective cover in front of the module. Connect the power supply cable to the X10 connector on the ASIC board and to the X2 connector on the rear side of the control unit.

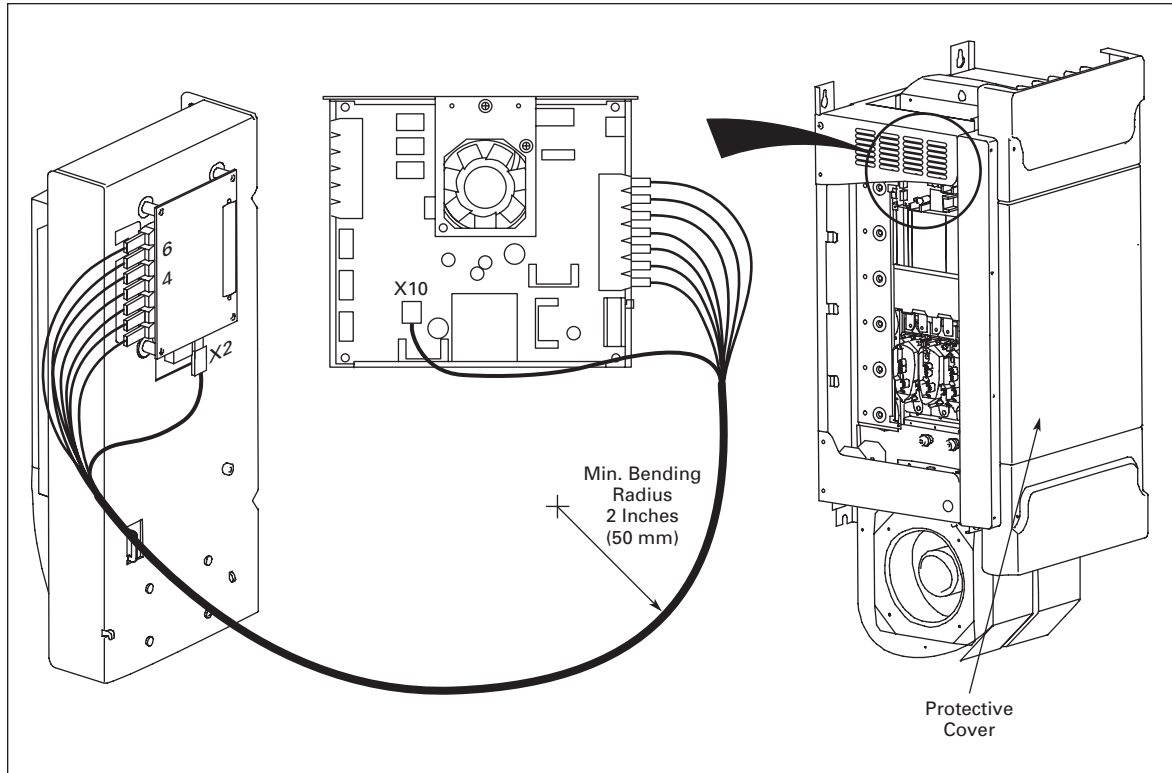

Figure 7-3: Connecting the Power Supply and Control Cables to the Control Unit, FR10 and FR11

Each fiber optic cable has a number 1 – 7 marked on the cable shield at both cable ends. Connect each cable to the connectors marked with the same number 1 – 7 on the ASIC board and on the rear side of the control unit. The list of the optic signals can be found in **Appendix B**.

April 2006

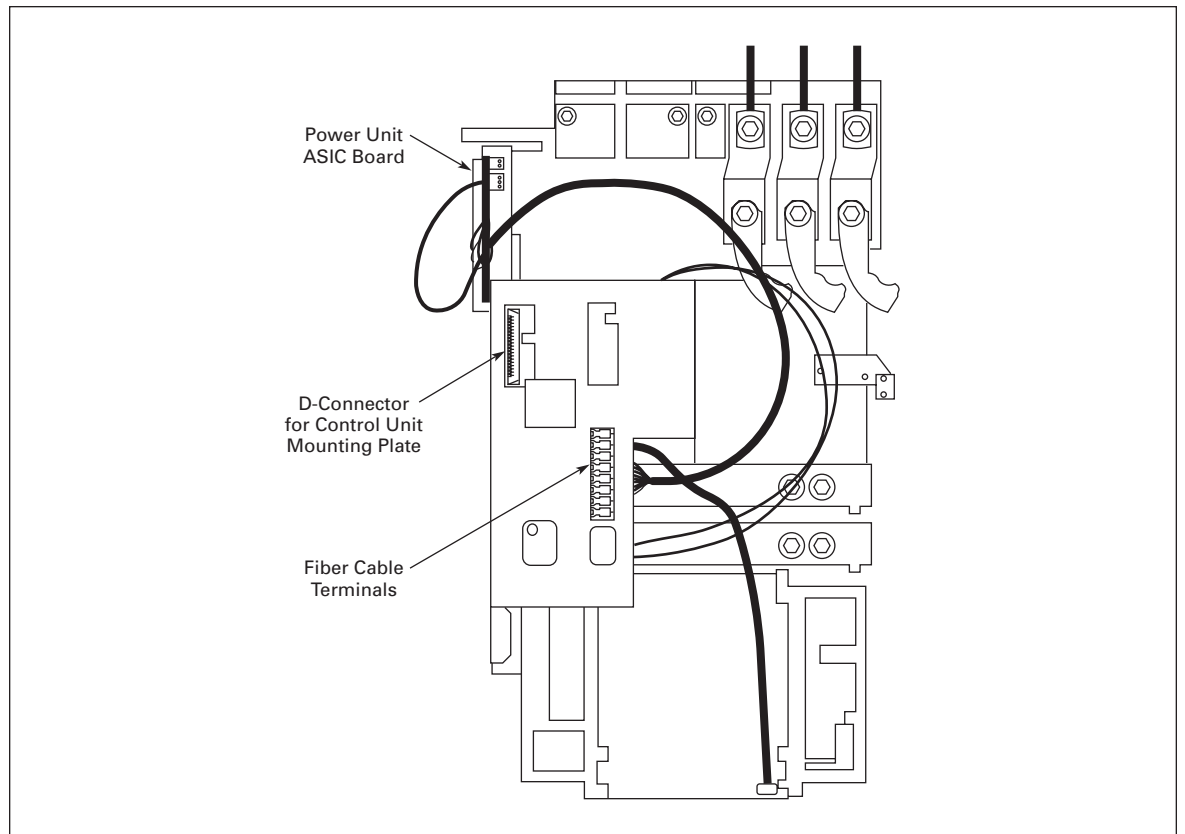

Figure 7-4: View Behind the Protective Cover

⚠ CAUTION

Be careful when connecting the fiber optic cables! Connecting the wires incorrectly will damage power electronic components.

Note: The minimum bending radius for optical cables is 2 Inches (50 mm).

Fix the cable bundle at two or more points, at least one at each end, to prevent damage to the cables.

Fasten the protective cover on the power unit when the work is finished.

Frame FR12

The control unit uses 24V DC supplied from the ASIC board, which is located on the left side of the power unit 1. To access the board, remove the protective cover in front of the power module. Connect the power supply cable to the X10 connector on the ASIC board and to the X2 connector on the rear side of the control unit.

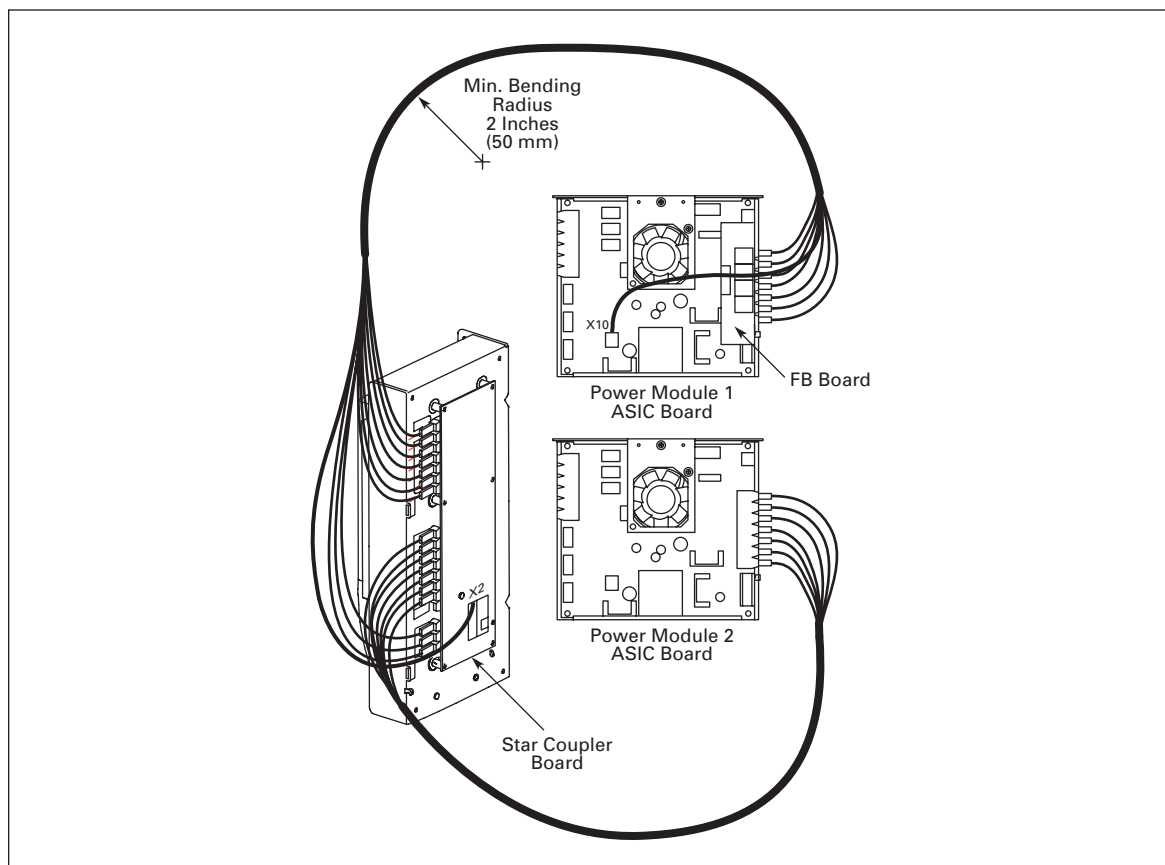

Figure 7-5: Connecting the Power Supply and Control Cables to the Control Unit, FR12

Each fiber optic cable has a number 1 – 8 and 11 – 18 marked on the cable shield at both cable ends. Connect each cable to the connectors marked with the same number on the ASIC board and on the rear side of the control unit. Additionally, you may have to connect the four fiber cables from the feedback board to the star coupler board. The list of the optic signals can be found in **Appendix B**.

April 2006

Frame FR13

The control unit uses 24V DC supplied from the ASIC board, shown in **Figure 7-6**. To access the board, remove the cover of the terminal compartment. In case you have received the power supply cable separately, connect it to the X10 terminal on the ASIC board. To access the ASIC board you also have to remove the protective cover. The other end of the power supply cable connects to the X2 connector on the rear side of the control unit. See **Figure 7-3**.

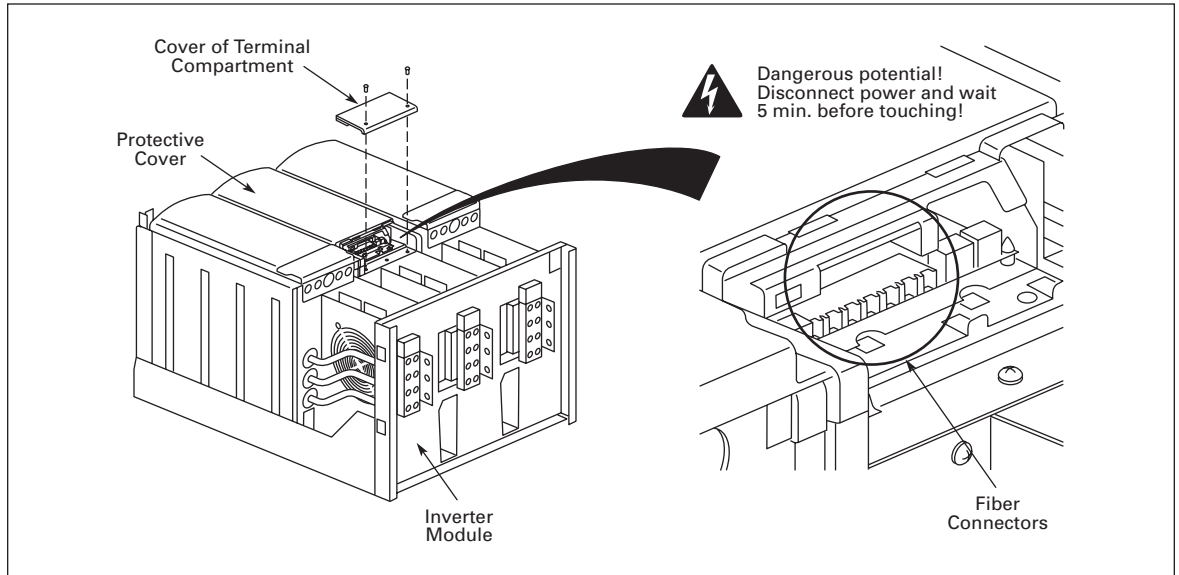

Figure 7-6: Connecting the Power Supply and Control Cables, FR13

Each fiber optic cable has a number 1 – 7 marked on the cable shield at both cable ends. Connect each cable to the connectors marked with the same number 1 – 7 on the ASIC board and on the rear side of the control unit. The list of the optic signals can be found in **Appendix B**.

CAUTION

Be careful when connecting the fiber optic cables! Connecting the wires incorrectly may damage power electronic components.

Note: The minimum bending radius for optical cables is 2 Inches (50 mm).

Fix the cable bundle at two or more points, at least one at each end, to prevent damage to the cables.

Fasten the removed cover(s) on the inverter module when the work is finished.

Frame FR14

The control unit uses 24V DC supplied from the ASIC board, shown in **Figure 7-7**. To access the board, remove the cover of the terminal compartment. In case you have received the power supply cable separately, connect it to the X10 terminal on the ASIC board. To access the ASIC board you also have to remove the protective cover, see figure below. The other end of the power supply cable connects to the X2 connector on the rear side of the control unit. See **Figure 7-5**.

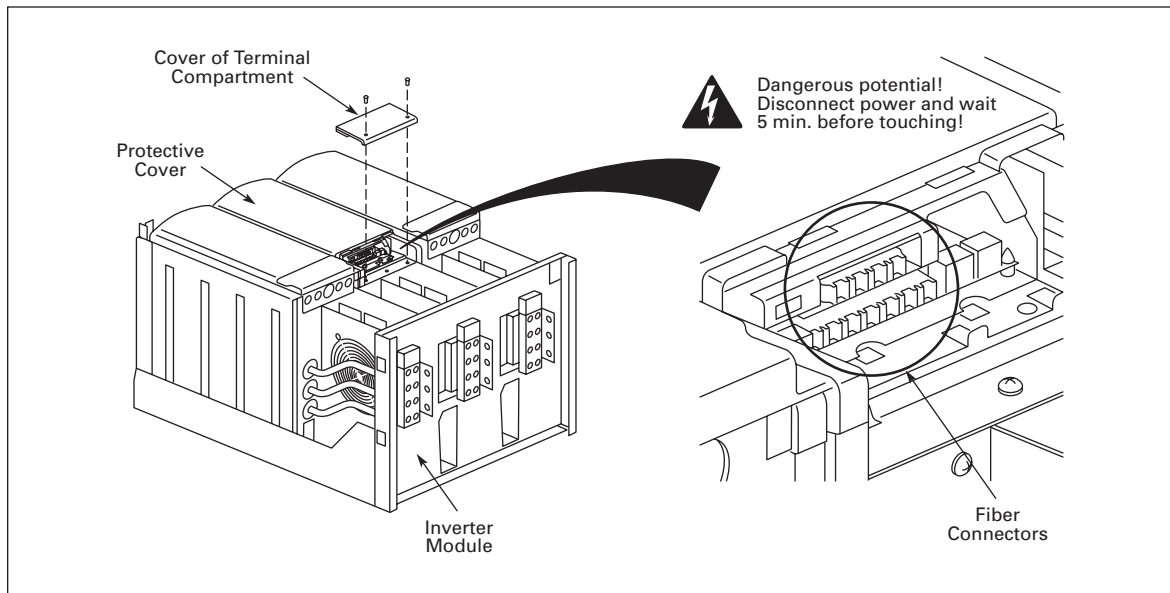

Figure 7-7: Connecting the Power Supply and Control Cables, FR14

Each fiber optic cable has a number 1 – 7 and 11 – 17 marked on the cable shield at both cable ends. Connect each cable to the connectors marked with the same number on the ASIC board and on the rear side of the control unit. Additionally, you may have to connect the four fiber cables from the feedback board to the star coupler board. The list of the optic signals can be found in **Appendix B**.

April 2006

Control Connections from NFE Units to Inverter Module(s)

The delivery of FR13 and FR14 drives contains a set of conductors that are used to link the NFE units and the inverter module(s) to each other. The conductors run in a sleeving and all you have to do is to insert the connectors into appropriate terminals.

The terminals are located under the terminal compartment cover that you will have to remove first. The sleeving is then directed through the rubber grommet and finally connected to the correct terminal. See **Figures 7-8 to 7-12**.

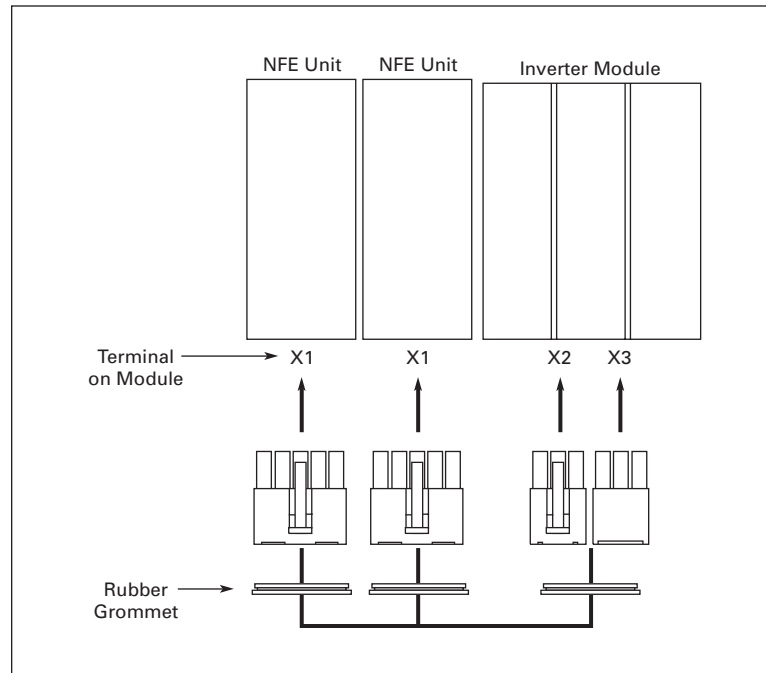

Figure 7-8: Linking the Modules; See Figure in Table 2-4

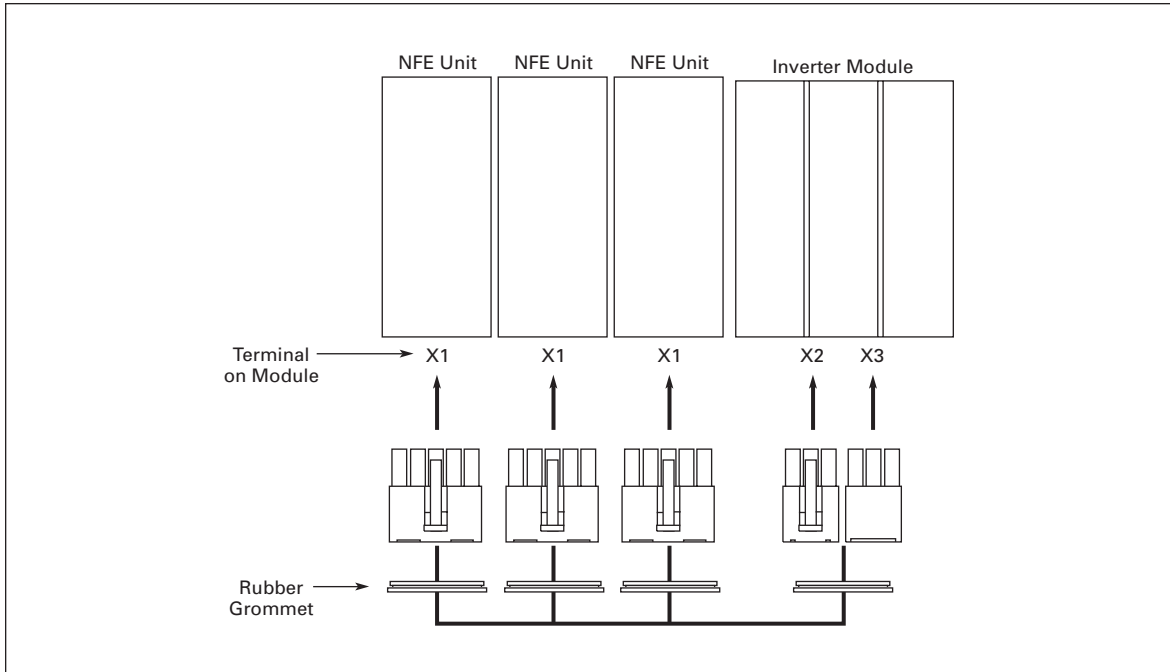

Figure 7-9: Linking the Modules; See Figure in Table 2-5

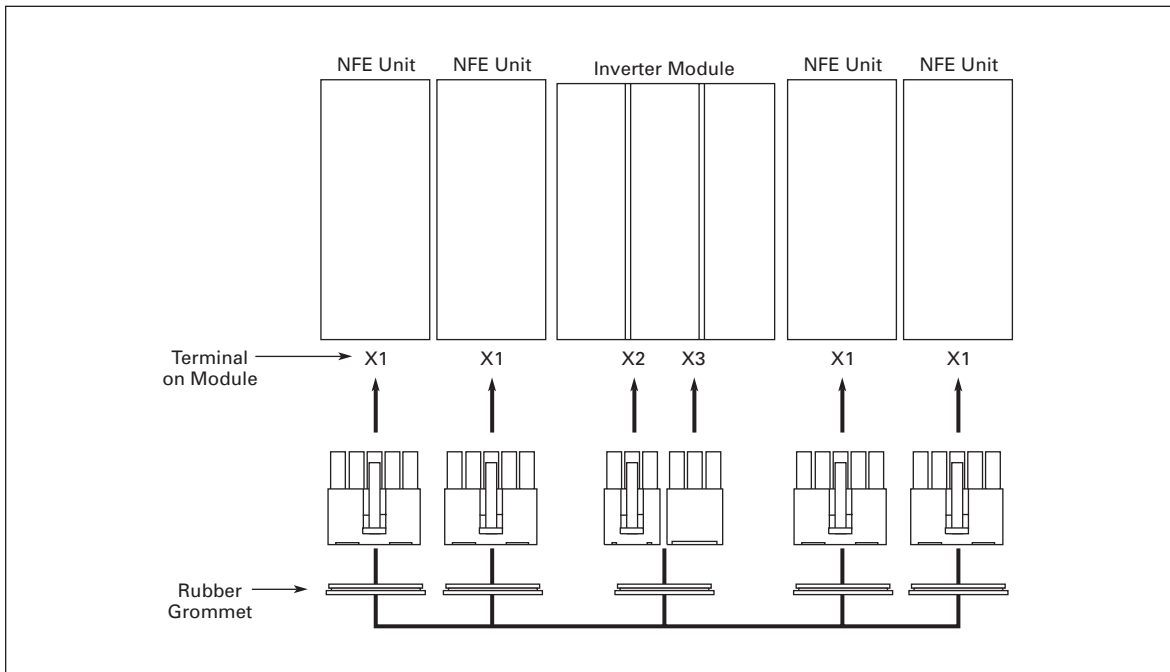

Figure 7-10: Linking the Modules; See Figure in Table 2-6

April 2006

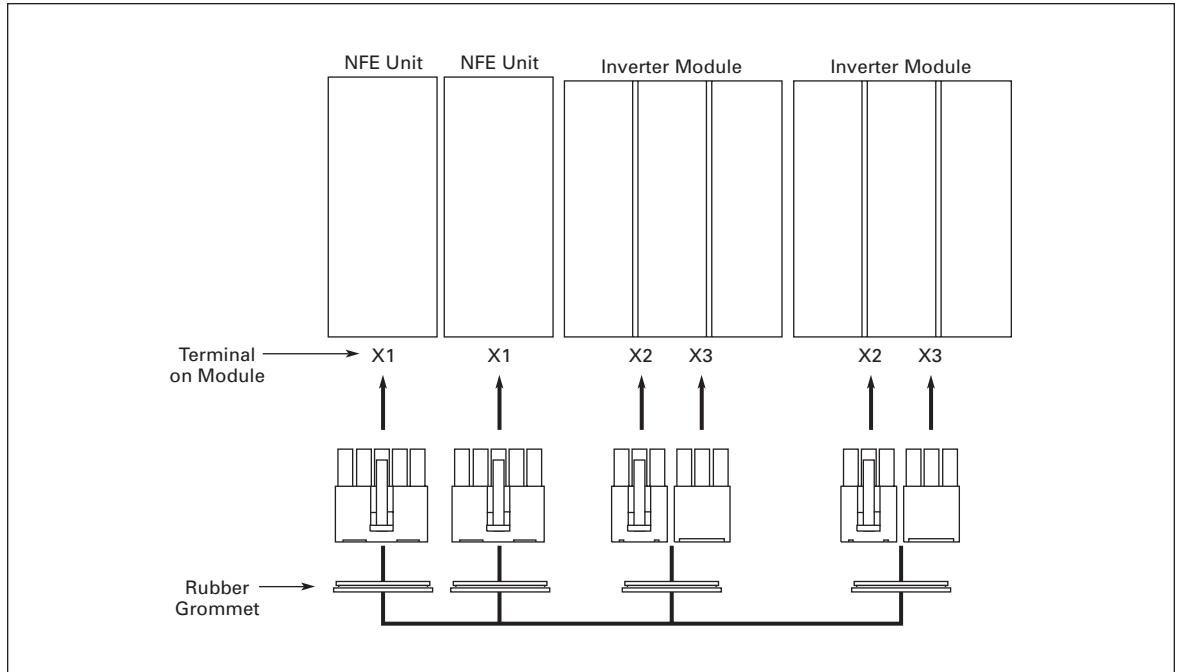

Figure 7-11: Linking the Modules; See Figure in Table 2-7

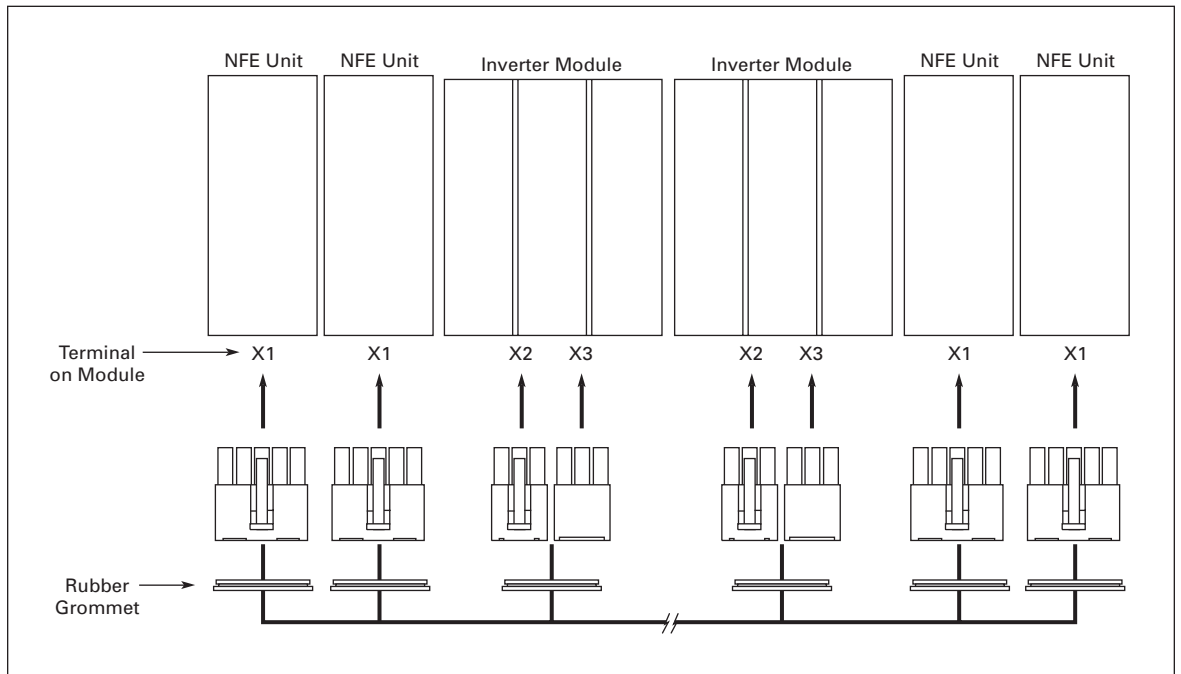

Figure 7-12: Linking the Modules; See Figure in Table 2-8

April 2006

Chapter 8 — Preparing for External Power Connections

Installing Mounting Plate and Input Terminals, FR10 – FR12

For further installation of other devices (breakers, fuses, EMC grounding), it is recommended that an installation plate be mounted in front of the AC choke, leaving the bottom part open for air circulation. Install input terminals on the plate and connect them to the input terminals (the uppermost terminals) of the AC choke using bus bars or flexible bus bars according to **Table 8-1**.

Table 8-1: Copper Busbar Dimensions

Product	Cu Busbar Size	Busbars Total
Voltage Range 400 – 500V		
SPX250	30 x 6 mm	3
SPX300	40 x 6 mm	3
SPX350	40 x 6 mm	3
SPX400 – SPX550	30 x 6 mm	6
SPX600 – SPX700	40 x 6 mm	6
Voltage Range 525 – 690V		
SPX200 – SPX300	30 x 6 mm	3
SPX400 – SPX450	40 x 6 mm	3
SPX500 – SPX700	30 x 6 mm	6

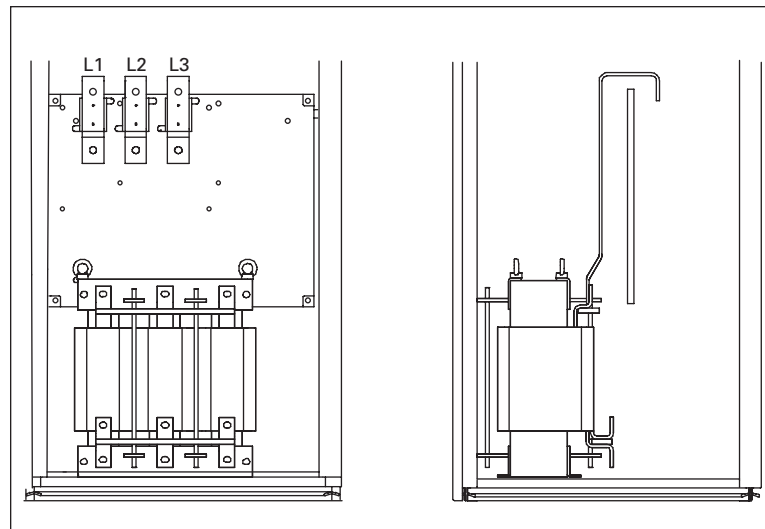

Figure 8-1: Power Input Terminals

Routing the Supply Busbars, FR13 and FR14

See **Figure 8-2** for how to route the incoming busbars to the AC chokes in the cabinet. **Table 8-2** gives the dimensions for the used busbars. Install a busbar on each pole of the AC choke, see **Figure 6-3**.

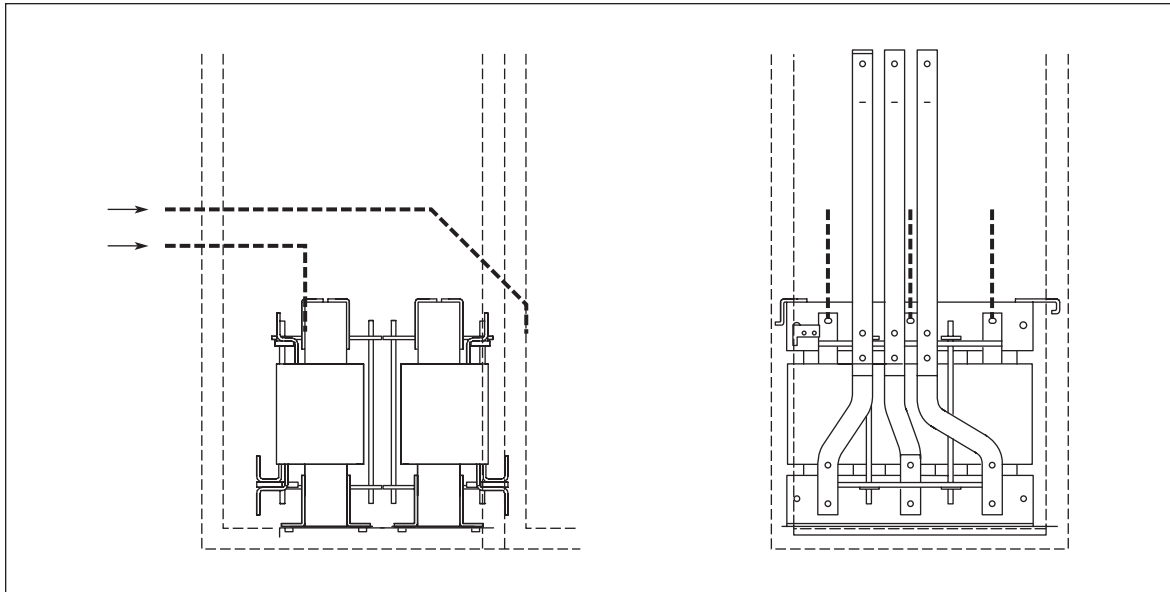

Figure 8-2: Route for Incoming Busbars Seen from the Front (Left) and Side (Right)

Note: We recommend closing the cabinet wall between the NFE cabinet and the inverter cabinet in order to avoid hot air circulation and consequential overheating.

Table 8-2: Copper Busbar Dimensions

Product	Cu Busbar Size	Busbars Total
Voltage Range 400 – 500V		
SPX800	40 x 6 mm	6
SPX900 – SPXH10 (6-pulse)	40 x 6 mm	9
SPX900 – SPXH10 (12-pulse)	40 x 6 mm	12
SPXH12 – SPXH16	40 x 6 mm	12
Voltage Range 525 – 690V		
SPX800 – SPXH10	40 x 6 mm	6
SPXH13 – SPXH20	40 x 6 mm	12

April 2006

Installing Fuses

The delivery of IP00 drive contains no internal fuses. To protect the device and allow the installation of a main switch in the enclosure, it is recommended that a fuse switch be installed. Use Bussman aR type fuses according to **Table 8-3**, and install them in the same enclosure as the frequency converter, or in another enclosure in the immediate vicinity. Fuse installation instructions are given on **Page 8-6**. See **Appendix C** for recommendations on other fuse types.

Table 8-3: Bussman Fuse Recommendations, FR10 – FR12

Frame	Nominal Current (A)	DIN43620		DIN43653 (110 mm)		Flush End Contacts (Metric)		Fuse I _n (A)	Qty. of Fuses per Drive
		aR Fuse Part No.	Fuse Size	aR Fuse Part No.	Fuse Size	aR Fuse Part No.	Fuse Size		
Mains Voltage 380 – 500V									
FR10	385	170M5813	DIN 2	170M5213	2TN/110	170M5463	2BKN/50	700	3
FR10	385	170M5813	DIN 2	170M5213	2TN/110	170M5463	2BKN/50	700	6
FR10	460	170M8547	3SHT ②	170M6216	3TN/110	170M6466	3BKN/50	1250	3
FR10	460	170M5813	DIN 2	170M5213	2TN/110	170M5463	2BKN/50	700	6
FR10	520	170M8547	3SHT ②	170M6216	3TN/110	170M6466	3BKN/50	1250	3
FR10	520	170M5813	DIN 2	170M5213	2TN/110	170M5463	2BKN/50	700	6
FR11	590	170M5813	DIN 2	170M5213	2TN/110	170M5463	2BKN/50	700	6
FR11	650	170M5813	DIN 2	170M5213	2TN/110	170M5463	2BKN/50	700	6
FR11	730	170M5813	DIN 2	170M5213	2TN/110	170M5463	2BKN/50	700	6
FR12	820	170M8547	3SHT ②	170M6216	3TN/110	170M6466	3BKN/50	1250	6
FR12	920	170M8547	3SHT ②	170M6216	3TN/110	170M6466	3BKN/50	1250	6
FR12	1030	170M8547	3SHT ②	170M6216	3TN/110	170M6466	3BKN/50	1250	6
FR12 DC-link	①	170M5813	DIN 2	170M5213	2TN/110	170M5463	2BKN/50	700	2

① In FR12 12-pulse drive or if FR12 (6- or 12-pulse) has internal brake; DC-links between units are connected together. If connected together; there must be DC-link fuses in DC-minus and DC-plus poles between the units. (In 6-pulse drive without internal brake, DC-links between units are separate and there is no need for fuses.)

② SHT fuses can be assembled into same size DIN fuse base.

Data written in shaded bold refer to 12-pulse drives (6-phase supply).

The aR fuses are thermally rated into switch fuse in 50°C ambient temperature.

Table 8-3: Bussman Fuse Recommendations, FR10 – FR12 (Continued)

Frame	Nominal Current (A)	DIN43620		DIN43653 (110 mm)		Flush End Contacts (Metric)		Fuse I _n (A)	Qty. of Fuses per Drive	
		aR Fuse Part No.	Fuse Size	aR Fuse Part No.	Fuse Size	aR Fuse Part No.	Fuse Size			
Mains Voltage 525 – 690V										
FR10	261	170M5813	DIN 2	170M5213	2TN/110	170M5463	2BKN/50	700	3	
FR10	261	170M5813	DIN 2	170M5213	2TN/110	170M5463	2BKN/50	700	6	
FR10	325	170M5813	DIN 2	170M5213	2TN/110	170M5463	2BKN/50	700	3	
FR10	325	170M5813	DIN 2	170M5213	2TN/110	170M5463	2BKN/50	700	6	
FR10	385	170M5813	DIN 2	170M5213	2TN/110	170M5463	2BKN/50	700	3	
FR10	385	170M5813	DIN 2	170M5213	2TN/110	170M5463	2BKN/50	700	6	
FR10	416	170M5813	DIN 2	170M5213	2TN/110	170M5463	2BKN/50	700	3	
FR10	416	170M5813	DIN 2	170M5213	2TN/110	170M5463	2BKN/50	700	6	
FR11	460	170M8547	3SHT ^②	170M6216	3TN/110	170M6466	3BKN/50	1250	3	
FR11	460	170M5813	DIN 2	170M5213	2TN/110	170M5463	2BKN/50	700	6	
FR11	502	170M8547	3SHT ^②	170M6212	3TN/110	170M6466	3BKN/50	1250	3	
FR11	502	170M5813	DIN 2	170M5213	2TN/110	170M5463	2BKN/50	700	6	
FR11	590	170M5813	DIN 2	170M5213	2TN/110	170M5463	2BKN/50	700	6	
FR11	590	170M5813	DIN 2	170M5213	2TN/110	170M5463	2BKN/50	700	6	
FR12	650	170M5813	DIN 2	170M5213	2TN/110	170M5463	2BKN/50	700	6	
FR12	750	170M5813	DIN 2	170M5213	2TN/110	170M5463	2BKN/50	700	6	
FR12	820	170M5813	DIN 2	170M5213	2TN/110	170M5463	2BKN/50	700	6	
FR12 DC-link	^①	170M6202	3SHT ^②	170M5986	2TN/110	170M8604	3BKN/75	500	2	

^① In FR12 12-pulse drive or if FR12 (6- or 12-pulse) has internal brake; DC-links between units are connected together. If connected together; there must be DC-link fuses in DC-minus and DC-plus poles between the units. (In 6-pulse drive without internal brake, DC-links between units are separate and there is no need for fuses.)

^② SHT fuses can be assembled into same size DIN fuse base.

Data written in shaded bold refer to 12-pulse drives (6-phase supply).

The aR fuses are thermally rated into switch fuse in 50°C ambient temperature.

April 2006

Table 8-4: Fuse Recommendations, FR13 – FR14

Frame	Nominal Current (A)	Fuses with Flush End Contact (Metric)		Fuses with Flush End Contact (US)		Fuse I _n (A)	Qty. of DC Fuses per Drive	Qty. of AC Fuses per Drive
		Fuse Part No. (aR) (AC/DC)	Fuse Size	Fuse Part No. (aR)	Fuse Size			
Mains voltage 380-500 V								
FR13	1150	170M6466	3BKN/50	170M6566	3GKN/50	1250	4	6
FR13	1150	170M6466	3BKN/50	170M6566	3GKN/50	1250	4	6
FR13	1300	170M6466	3BKN/50	170M6566	3GKN/50	1250	6	9
FR13	1300	170M6466	3BKN/50	170M6566	3GKN/50	1250	6	12
FR13	1450	170M6466	3BKN/50	170M6566	3GKN/50	1250	6	9
FR13	1450	170M6466	3BKN/50	170M6566	3GKN/50	1250	6	12
FR14	1770	170M6466	3BKN/50	170M6566	3GKN/50	1250	8	12
FR14	1770	170M6466	3BKN/50	170M6566	3GKN/50	1250	8	12
FR14	2150	170M6466	3BKN/50	170M6566	3GKN/50	1250	8	12
FR14	2150	170M6466	3BKN/50	170M6566	3GKN/50	1250	8	12
Mains voltage 525-690 V								
FR13	920	170M6466 (AC) 170M8610 (DC)	3BKN/50 3BKN/75	170M6566 (AC)	3GKN/50	1250 1000	4	6
FR13	920	170M6466 (AC) 170M8610 (DC)	3BKN/50 3BKN/75	170M6566 (AC)	3GKN/50	1250 1000	4	6
FR13	1030	170M6466 (AC) 170M8610 (DC)	3BKN/50 3BKN/75	170M6566 (AC)	3GKN/50	1250 1000	4	6
FR13	1030	170M6466 (AC) 170M8610 (DC)	3BKN/50 3BKN/75	170M6566 (AC)	3GKN/50	1250 1000	4	6
FR13	1180	170M6466 (AC) 170M8610 (DC)	3BKN/50 3BKN/75	170M6566 (AC)	3GKN/50	1250 1000	4	6
FR13	1180	170M6466 (AC) 170M8610 (DC)	3BKN/50 3BKN/75	170M6566 (AC)	3GKN/50	1250 1000	4	6
FR14	1500	170M6466 (AC) 170M8610 (DC)	3BKN/50 3BKN/75	170M6566 (AC)	3GKN/50	1250 1000	6	9
FR14	1500	170M6466 (AC) 170M8610 (DC)	3BKN/50 3BKN/75	170M6566 (AC)	3GKN/50	1250 1000	8	12
FR14	1900	170M6466 (AC) 170M8610 (DC)	3BKN/50 3BKN/75	170M6566 (AC)	3GKN/50	1250 1000	8	12
FR14	1900	170M6466 (AC) 170M8610 (DC)	3BKN/50 3BKN/75	170M6566 (AC)	3GKN/50	1250 1000	8	12
FR14	2250	170M6466 (AC) 170M8610 (DC)	3BKN/50 3BKN/75	170M6566 (AC)	3GKN/50	1250 1000	8	12
FR14	2250	170M6466 (AC) 170M8610 (DC)	3BKN/50 3BKN/75	170M6566 (AC)	3GKN/50	1250 1000	8	12

Data written in shaded bold refer to 12-pulse drives (6-phase supply).
The aR fuses are thermally rated into switch fuse in 50°C ambient temperature.

Fuse Installation Instructions

In order to ensure reliable function of the fuse, make a proper installation and a good contact between the fuse and the connecting cables/busbars or the fuse holder. Furthermore, the generated heat will be better removed through a well-made connection. Follow the tightening torques given below. Eaton engineers recommend a fuse connection made with busbars.

Flush End Fuses

For all kinds of flush end fuses the fuse manufacturer recommends (screw in) studs according to DIN 913. The studs must be tightened carefully applying a torque of 5 – 8 Nm. As a general rule, the tightening torque for the nuts relates to the dimension of the threaded hole in the fuse contact. The recommended tightening torques for the fuses are given below:

Table 8-5: Tightening Torques for Flush End Fuses

Size/Type	Threaded Hole (mm)	Tightening Torque in-lb (Nm)
2B	M10	354 (40)
3B – 3G	M12	442 (50)

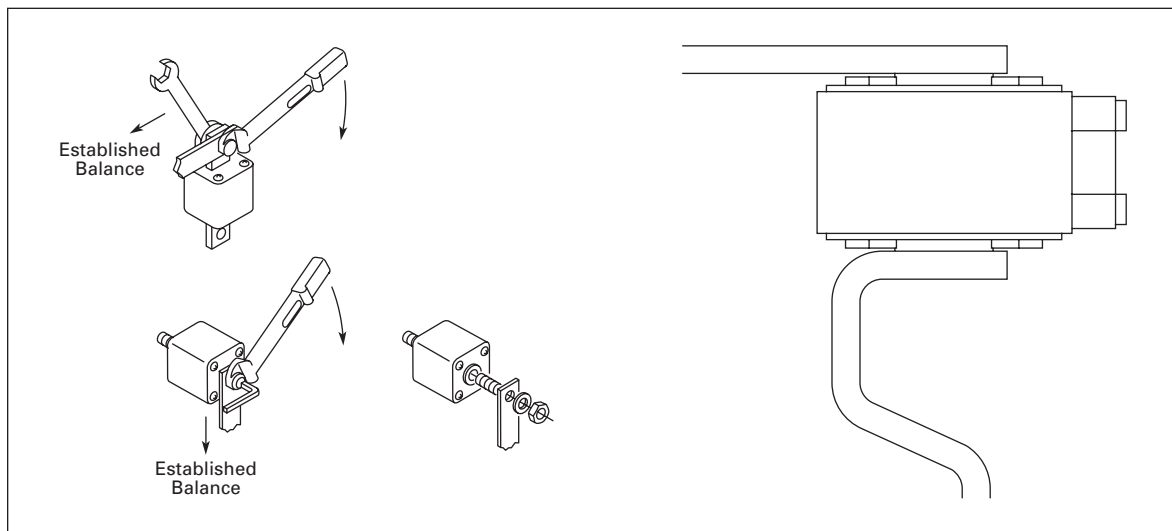

Figure 8-3: Installing Flush End Fuse; Busbar Connection Is Recommended (Right)

April 2006

Fuses with Contact Knives

Eaton engineers recommend two types of fuses with contact knives; fuses with slotted knives according to **DIN43653** and fuses with solid knives according to **DIN43620**. The former are mounted directly on busbars or in special fuse holders and the latter in spring-loaded fuse bases.

Use the biggest possible bolts/studs, nuts and washers (recommended) to tighten the DIN43653 fuses to a torque of 50 Nm.

The fuses according to DIN43653 have to be tightened in accordance with the specification provided with the base.

Installing EMC Grounding, FR10 to FR12

The output cables to the motor must be 360° EMC grounded. The EMC grounding clamps can, for instance, be installed on the mounting plate in front of the AC choke as shown in **Figure 8-4**. The EMC grounding clamps must be suited to the output cable diameter to give a 360° contact with the cables. Refer to the user manual for output cable diameters.

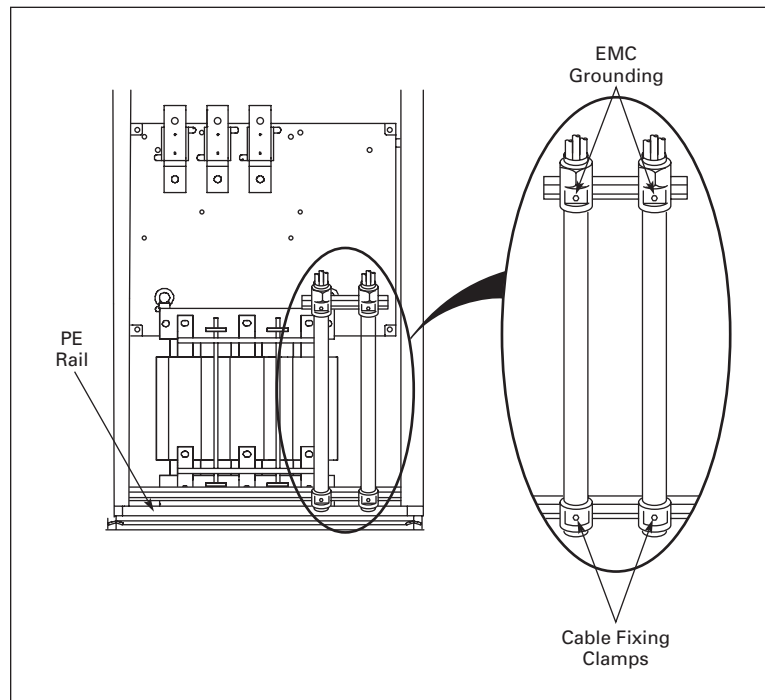

Figure 8-4: Installing EMC Grounding

Installation of Ferrite Rings (Option) on the Motor Cable

Slip only the phase conductors through the window; leave the cable screen below and outside the rings, see **Figure 8-5**. Separate the PE conductor. In case of parallel motor cables, reserve an equal amount of ferrite rings for each cable and feed all the phase conductors of one cable through one set of rings. Delivery includes fixed sets of ferrite rings.

When ferrite rings are used to attenuate the risk of bearing damages, the number of ferrites has to be 6 – 10 for a single motor cable and 10 per cable when the motor is supplied with parallel cables.

Note: The ferrite rings are only additional protection. The basic protection against bearing currents is an insulated bearing.

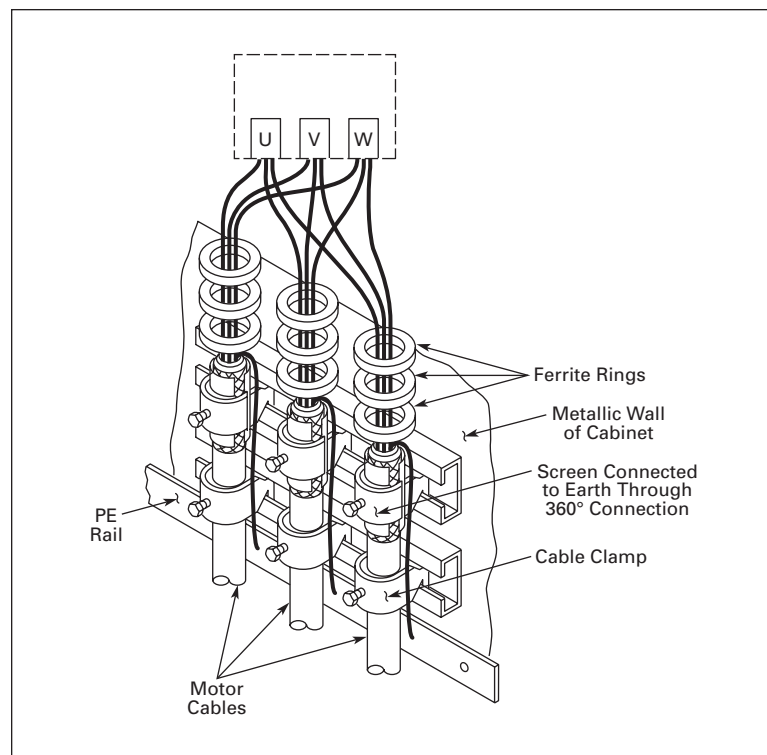

Figure 8-5: Installation of Ferrite Rings

Connecting Input and Output Power

Refer to the user manual, where input and output cables are specified.

April 2006

Chapter 9 — Arranging Air Cooling and Ventilation

⚠ CAUTION

It is of utmost importance for the operation and lifetime of the adjustable frequency converter that the enclosure is well ventilated to keep the temperature below maximum allowed operating temperature. Repeated overheating will shorten the lifetime of the converter.

Arranging Ventilation of the Enclosure

The enclosure door must be provided with air gaps for air intake. To achieve sufficient cooling inside the cabinet, the total area of free openings for incoming air must exceed the minimums in **Table 9-1**. For instance, there could be two screened gaps placed as in **Figure 9-1**. This layout ensures a sufficient air flow to the module fans as well as cooling of the additional components.

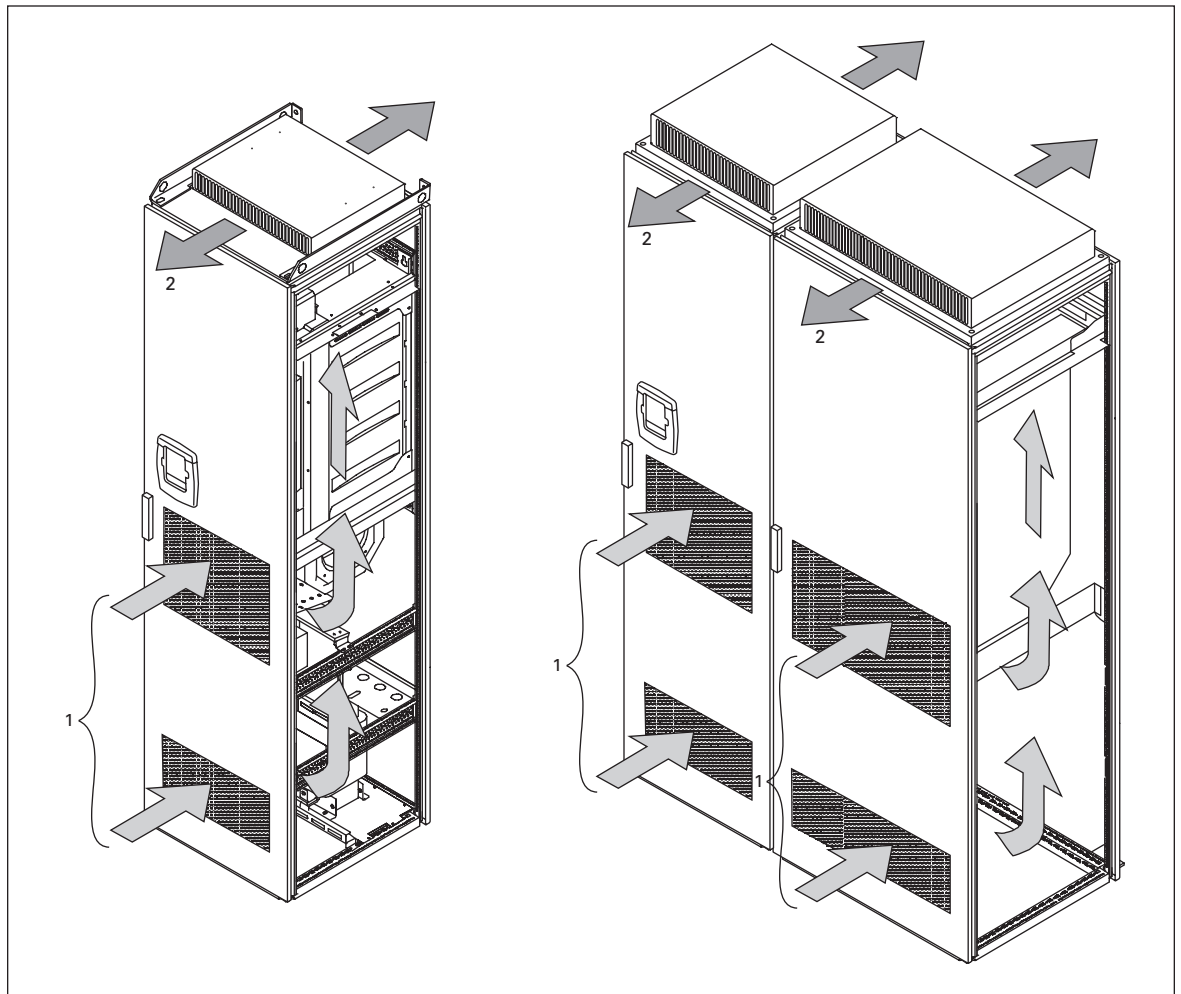

Figure 9-1: Ventilation Arrangements on the Cabinet (Examples)

Table 9-1: Minimum Ventilation Gaps

23.6 Inch (600 mm) Cabinet	31.5 Inch (800 mm) Cabinet
20 x 10 Inch (510 x 255 mm)	30 x 10 Inch (765 x 255 mm)
700 cm ²	1050 cm ²

Air outlet gaps must be situated on top of the cabinet. Minimum effective air outlet area is given in **Table 9-1**. The cooling arrangements inside the cabinet must be such that they prevent hot output air from mixing with the incoming fresh air (see below).

The ventilation gaps must fulfill the requirements set by the selected IP class. The examples in this manual apply to protection class IP21.

During operation, air is sucked in and circulated by a fan blower at the bottom of the power unit. If the power unit is placed in the upper part of the cabinet, the fan blower will be in the mid of the cabinet, at the height of the upper ventilation grid. See **Figure 9-2**.

Steering the Internal Air Flow

Cooling air must be sucked in through the ventilation gaps on the door and blown out at the top of the enclosure. To steer the hot air from the power unit to the outlet at the top of the enclosure and prevent it from circulating back to the fan blower, use either of the following arrangements:

1. Install a closed air duct from the power unit to the outlet on top of the enclosure (A in **Figures 9-2** and **9-3**).
2. Install shields in the gaps between the power unit and the cabinet walls (B in **Figure 9-2**). Place the shields below the air outlet gaps at the sides of the module. In FR12, close the opposing gaps in the upper part of the cabinets with a sheet metal plate to ensure proper cooling.

April 2006

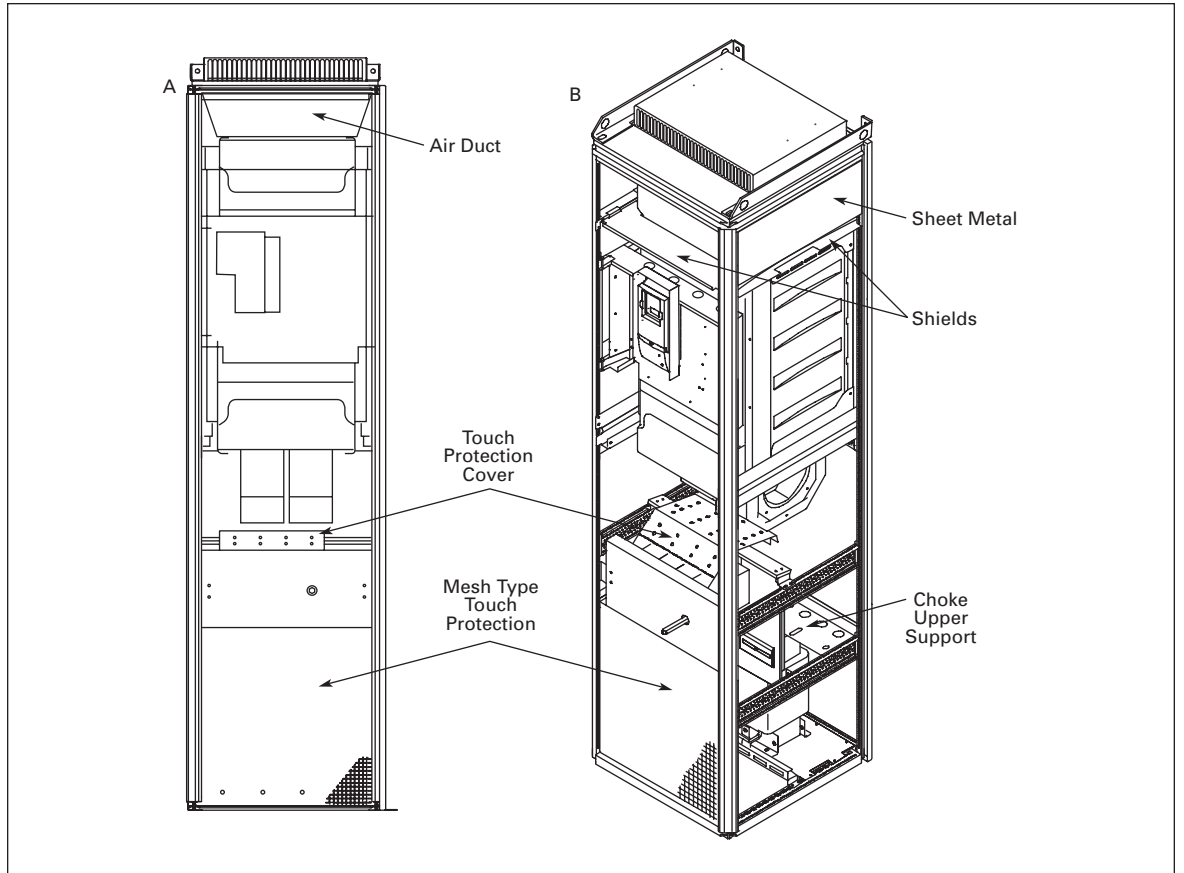

Figure 9-2: Arrangements for Steering Hot Air to the Outlet at the Top of the Cabinet — One Cabinet Solution

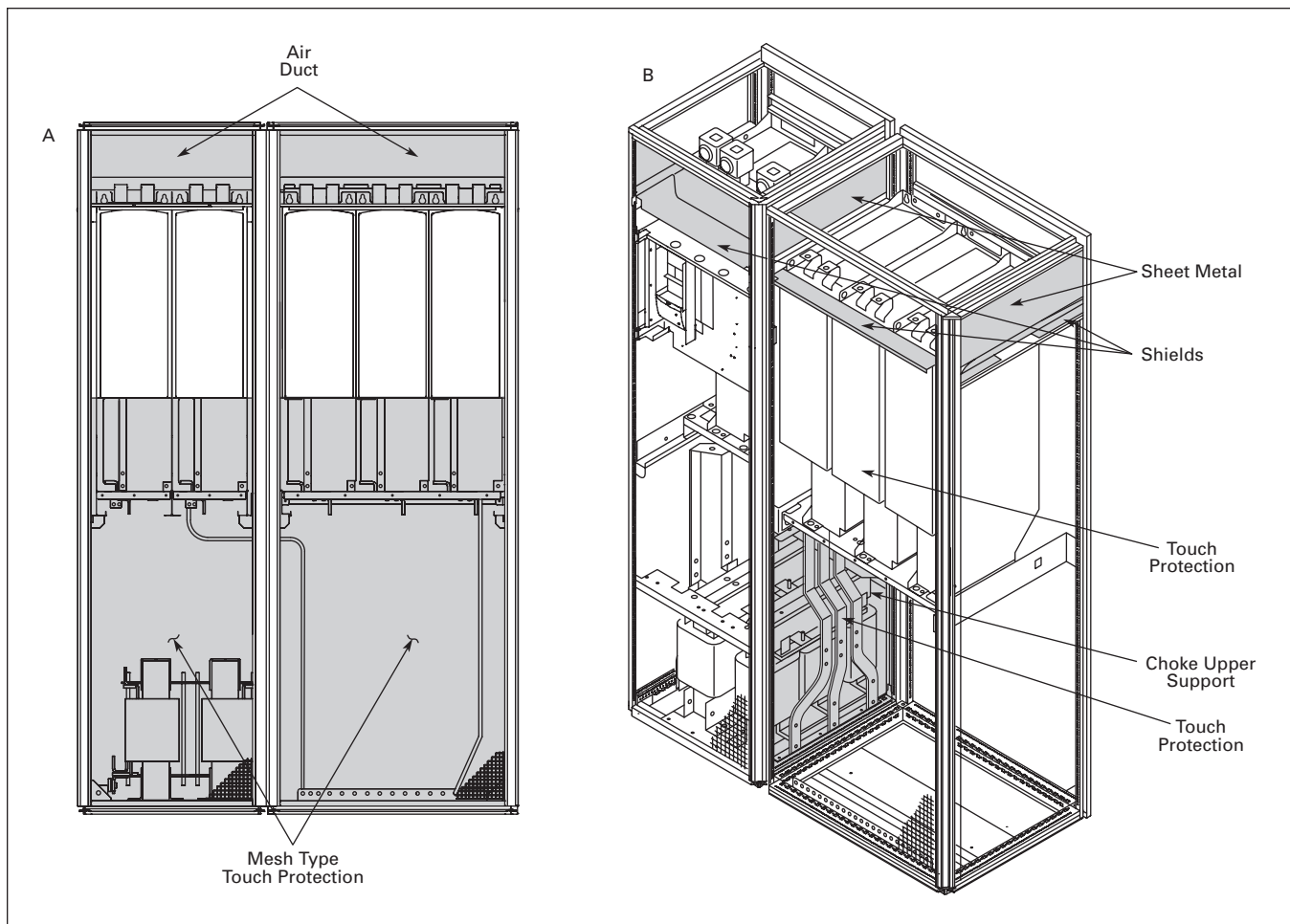

Figure 9-3: Arrangements for Steering Hot Air to the Outlet at the Top of the Cabinet — Several Cabinet Solution

Note: To allow free air circulation, the touch cover at the bottom of the cabinet must be of type meshed sheet metal screen. For the same reason, the busbar touch protection cover and the choke upper support must be equipped with holes. See **Figure 9-2**.

Note: If a flat roof is used, mount a V-shaped air guide on the underside of the roof to direct the air flow horizontally. See **Figure 9-4**.

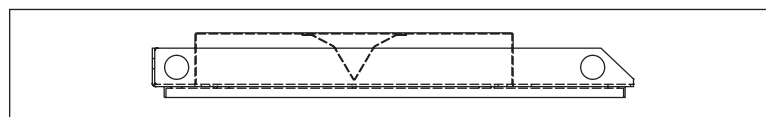

Figure 9-4: Roof Structure Seen from the Side

April 2006

Heat Dissipation

The efficiency of the adjustable frequency converter is a function of switching frequency, operating frequency and load (see user manual). Based on this information heat dissipation can be calculated at a certain operating point. For most cases the following general formula based on adjustable frequency converter load can be used for estimating the heat dissipation of the power module:

$$P_{loss} [kW] = P_{mot} [kW] \times 0.025$$

The following table shows the heat dissipation from the AC choke.

Table 9-2: Heat Dissipation from the AC Choke

Choke	Heat Dissipation
CHK0261	460W
CHK0400	570W
CHK0520	810W
CHK0650	890W

Temperatures Measured During Test Run

The following table shows the temperatures measured during a test run of a 520A/400V unit with nominal load @50 Hz. The test unit was installed in a Rittal TS8 enclosure using the guidelines described in this manual.

Table 9-3: Temperatures Measured During an Accepted Test Run

Measurement	Temperature	Note
Ambient Air	85.8°F (29.9°C)	Outside enclosure
Fan Intake Air	97.2°F (36.2°C)	—
Module Input Terminal	137.5°F (58.6°C)	L2-phase
Output Terminal	149.5°F (65.3°C)	V-phase
AC Choke	198.1°F (92.3°C)	L2 winding surface

April 2006

Appendix A — Dimensional Drawings

Power Unit

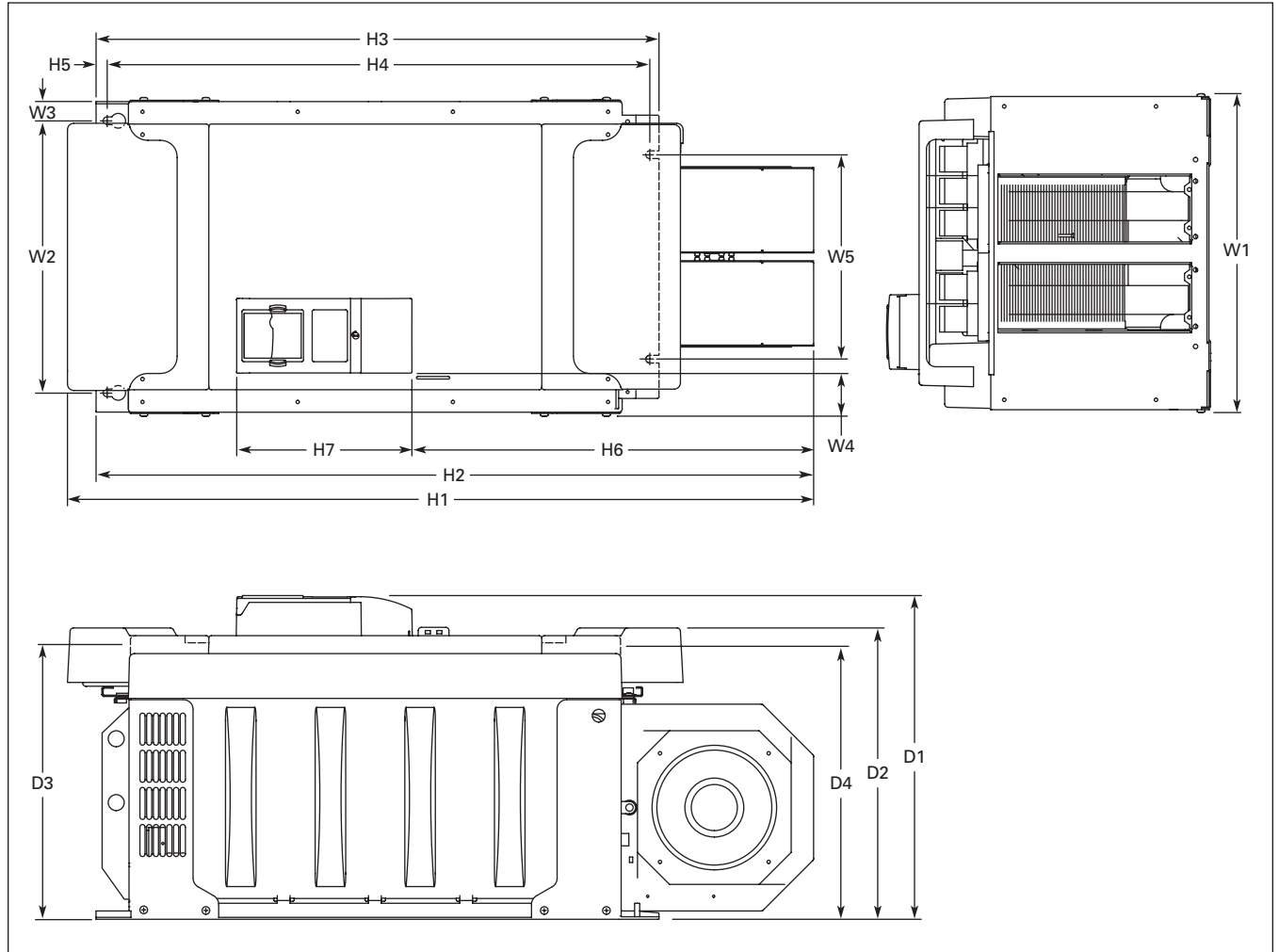

Figure A-1: SPX9000 Dimensions, FR10 Open Chassis

Table A-1: Dimensions for SPX9000, FR10 Open Chassis

Frame Size	Voltage	hp (I _H)	Approximate Dimensions in Inches (mm)																Weight Lbs. (kg)
			W1	W2	W3	W4	W5	H1	H2	H3	H4	H5	H6	H7	D1	D2	D3	D4	
FR10	480V	250 – 350	19.7	16.7	1.2	2.6	12.8	45.9	44.1	34.6	33.5	.7	24.7	10.8	19.9	17.9	16.7	16.6	518
	575V	200 – 300	(500)	(425)	(30)	(67)	(325)	(1165)	(1121)	(879)	(850)	(17)	(627)	(275)	(506)	(455)	(423)	(421)	(235)

Note: SPX9000 FR12 is built of two FR10 modules.

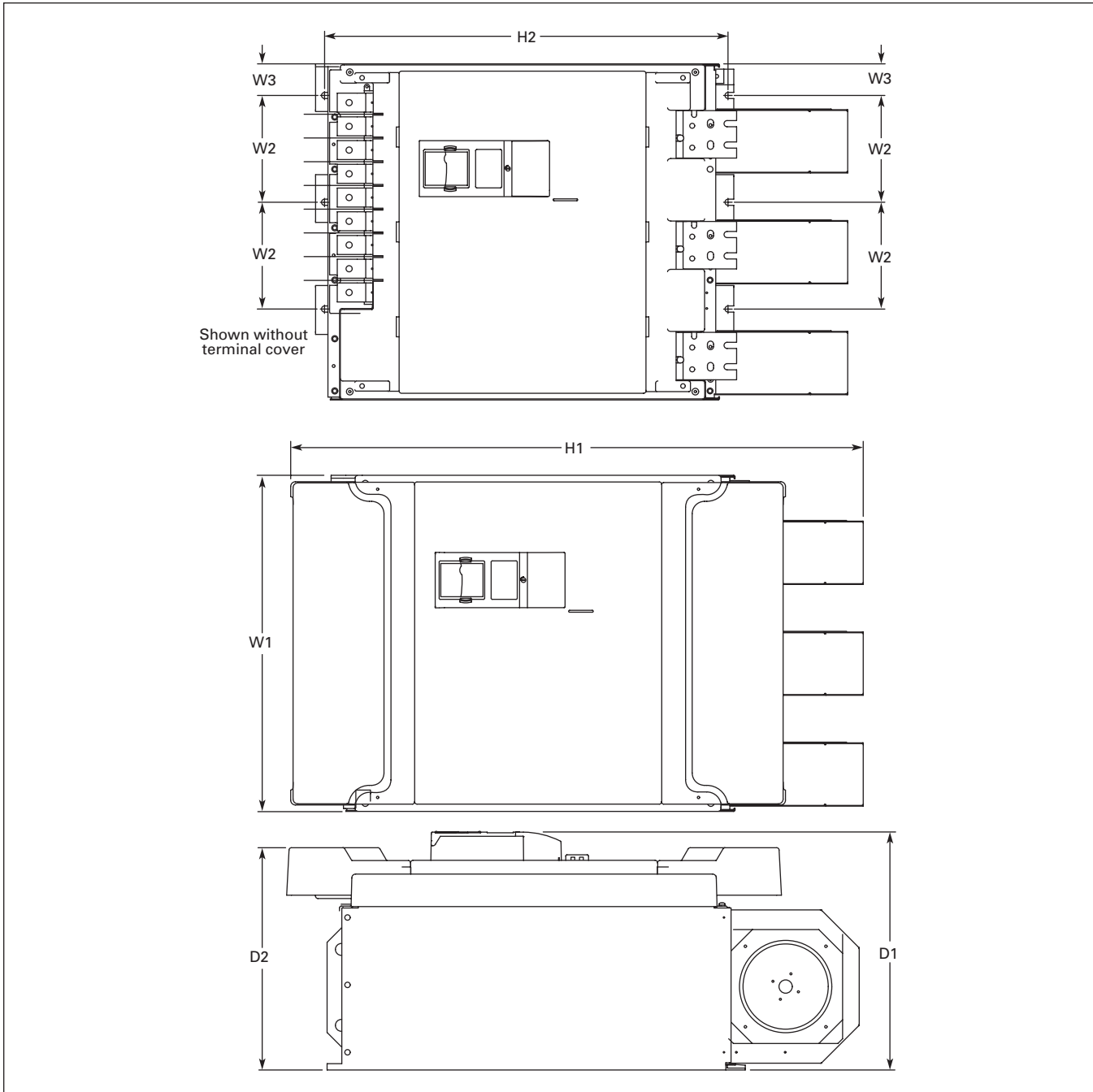

Figure A-2: SPX9000 Dimensions, FR11 Open Chassis

Table A-2: Dimensions for SPX9000, FR11 Open Chassis

Frame Size	Voltage	hp (I _H)	Approximate Dimensions in Inches (mm)						Weight Lbs. (kg)	
			W1	W2	W3	H1	H2	D1		D2
FR11	480V	400 – 550	27.9 (709)	8.6 (225)	2.6 (67)	45.5 (1155)	33.5 (850)	19.8 (503)	18.4 (468)	833 (378)
	575V	400 – 500								

April 2006

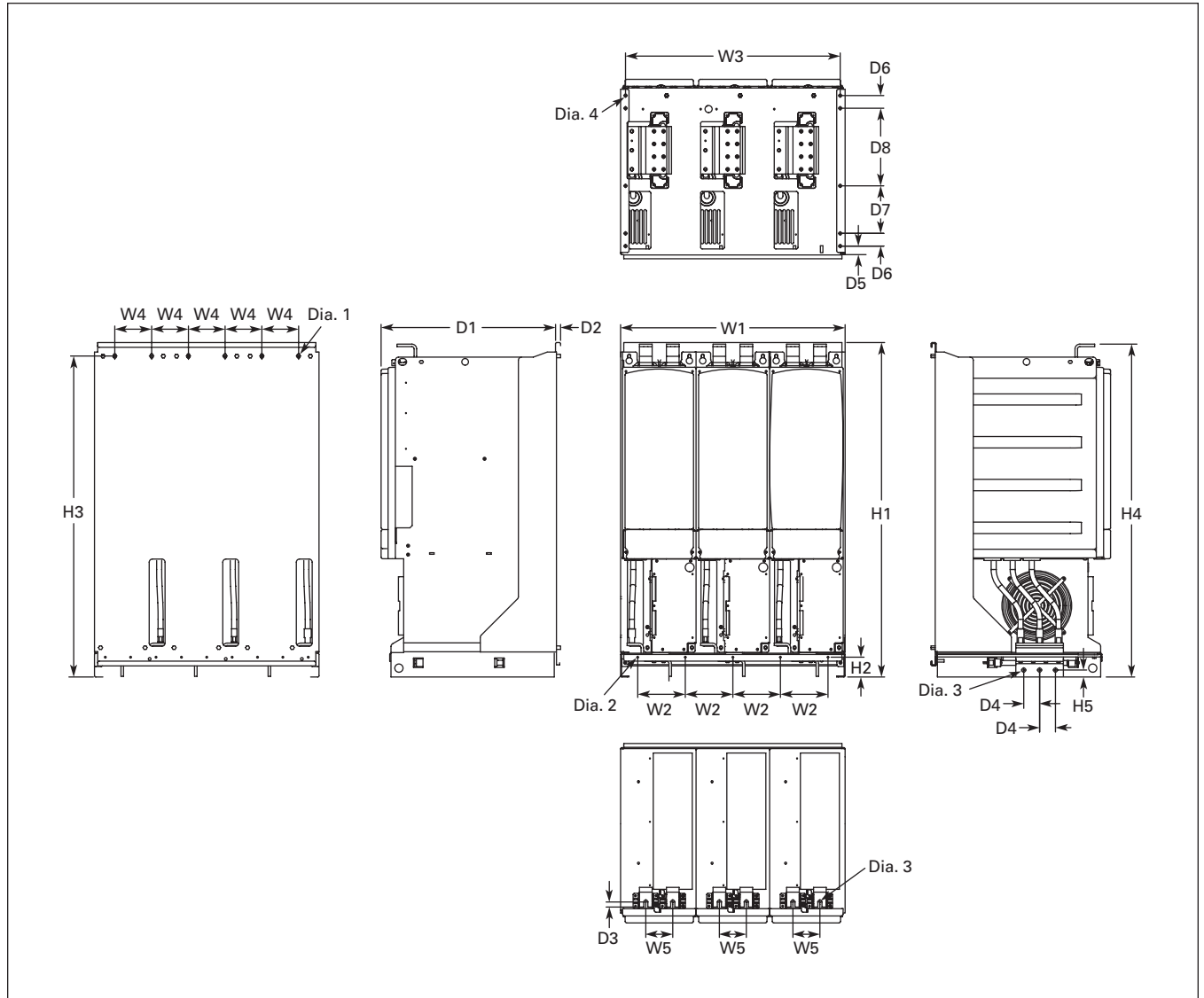

Figure A-3: SPX9000 Dimensions, FR13 Open Chassis Inverter

Table A-3: Dimensions for SPX9000, FR13 Open Chassis Inverter

Frame Size	Approximate Dimensions in Inches (mm)																		Weight Lbs. (kg)				
	W1	W2	W3	W4	W5	H1	H2	H3	H4	H5	D1	D2	D3	D4	D5	D6	D7	D8		Dia. 1	Dia. 2	Dia. 3	Dia. 4
FR13	27.87 (708)	5.91 (150)	26.65 (677)	4.57 (116)	3.35 (85)	41.54 (1055)	2.46 (62.5)	39.86 (1012.5)	41.34 (1050)	.79 (20)	21.77 (553)	.51 (13)	.63 (16)	1.97 (50)	1.06 (27)	1.57 (40)	5.91 (150)	9.64 (244.8)	.35x.59 (9x15)	.18 (4.6)	.51 (13)	.37 (9.5)	683 (310)

Note: 9000X FR14 is built of two FR13 modules.

Note: FR13 is built from an inverter module and a converter module.

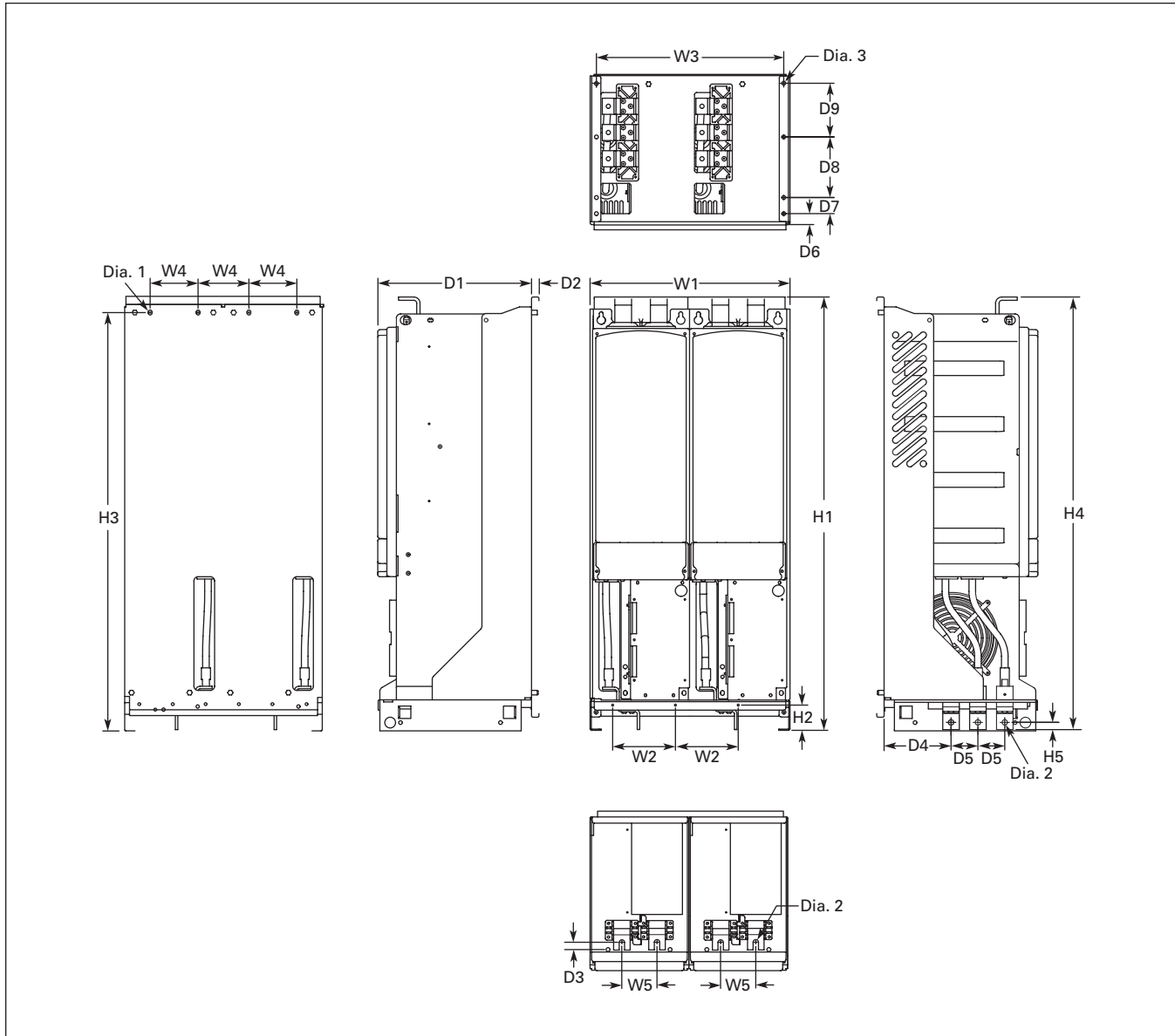

Figure A-4: SPX9000 Dimensions, FR13 Open Chassis Converter

Table A-4: FR13 — Number of Input Units

480V	hp	Input Modules	690V	hp	Input Modules
SPX800A0-4A2N1	800	2	SPX800A0-5A2N1	800	2
			SPX900A0-5A2N1	900	2
			SPXH10A0-5A2N1	1000	2

Table A-5: Dimensions for SPX9000, FR13 Open Chassis Converter

Frame Size	Approximate Dimensions in Inches (mm)																				Weight Lbs. (kg)		
	W1	W2	W3	W4	W5	H1	H2	H3	H4	H5	D1	D2	D3	D4	D5	D6	D7	D8	D9	Dia. 1		Dia. 2	Dia. 3
FR13	18.74 (476)	5.91 (150)	17.52 (445)	4.57 (116)	3.35 (85)	41.54 (1055)	2.46 (62.5)	39.86 (1012.5)	41.34 (1050)	.69 (17.5)	14.69 (373)	.51 (13)	.73 (18.5)	6.42 (163)	2.56 (65)	1.06 (27)	1.57 (40)	5.91 (150)	5.24 (133)	.35x.59 (9x15)	.51 (13)	.37 (9.5)	295 (134)

April 2006

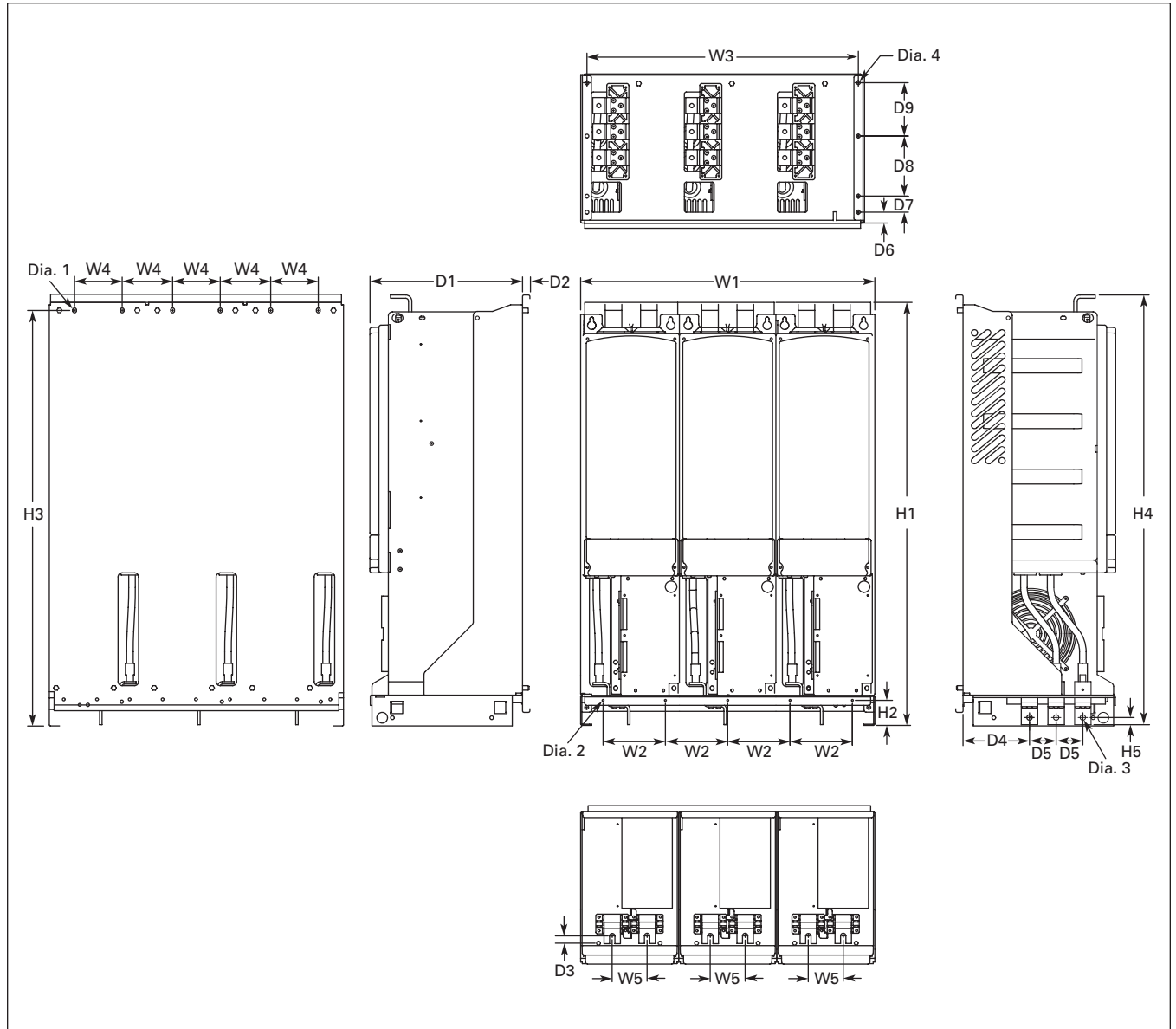

Figure A-5: SPX9000 Dimensions, FR13 Open Chassis Converter — 900/1000 hp 480V

Table A-6: FR13 — Number of Input Units

480V	hp	Input Modules
SPX900A0-4A2N1	900	3
SPXH10A0-4A2N1	1000	3

Table A-7: Dimensions for SPX9000, FR13 Open Chassis Converter — 900/1000 hp 480V

Frame Size	Approximate Dimensions in Inches (mm)																				Weight Lbs. (kg)			
	W1	W2	W3	W4	W5	H1	H2	H3	H4	H5	D1	D2	D3	D4	D5	D6	D7	D8	D9	Dia. 1		Dia. 2	Dia. 3	Dia. 4
FR13	27.87 (708)	5.91 (150)	26.65 (677)	4.57 (116)	3.35 (85)	41.54 (1055)	2.46 (62.5)	39.86 (1012.5)	41.34 (1050)	.69 (17.5)	14.69 (373)	.51 (13)	.73 (18.5)	6.42 (163)	2.56 (65)	1.06 (27)	1.57 (40)	5.91 (150)	5.24 (133)	.35x.59 (9x15)	.18 (4.6)	.51 (13)	.37 (9.5)	443 (201)

AC Choke — CHK0650

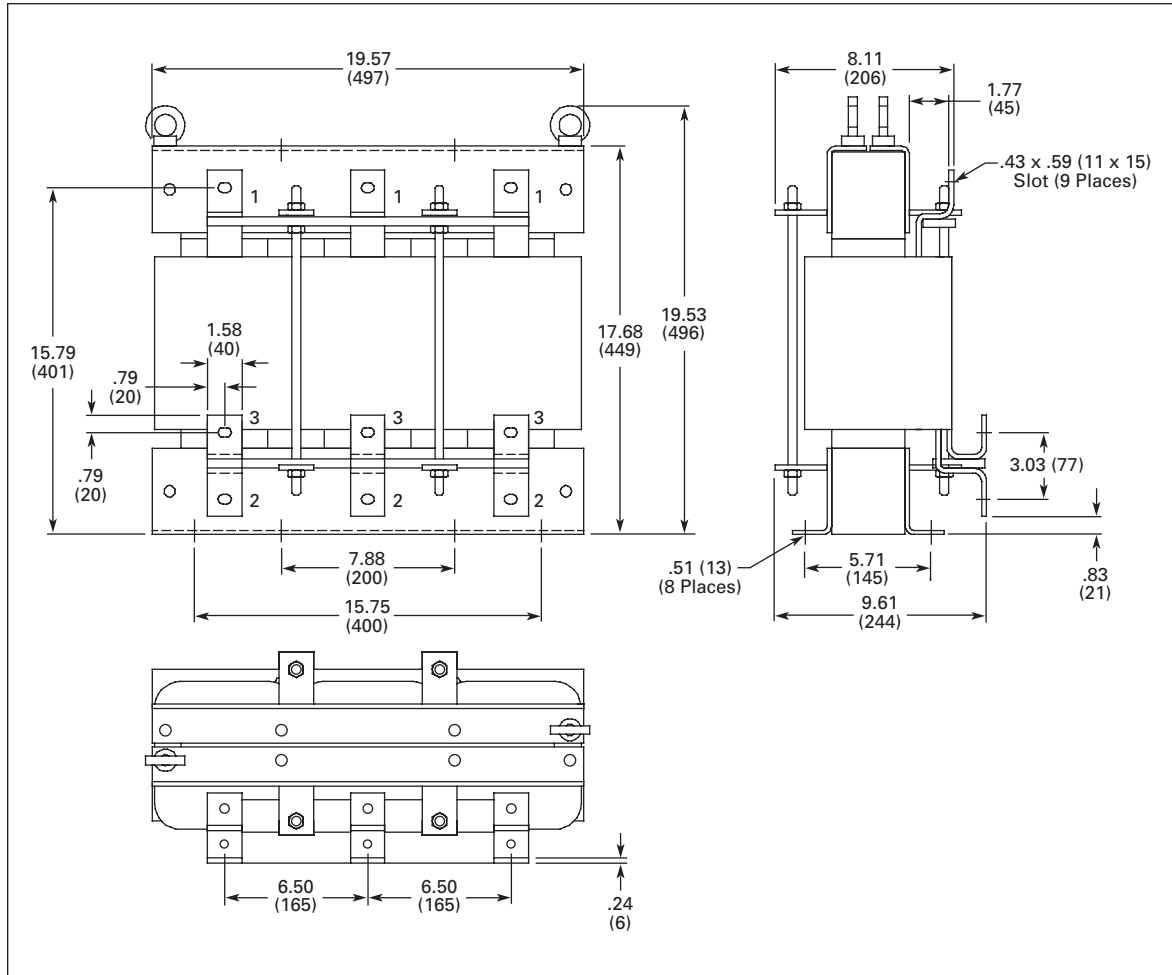

Figure A-6: AC Choke (CHK0650) Dimensions
Approximate Dimensions in Inches (mm)

AC Choke — CHK0400

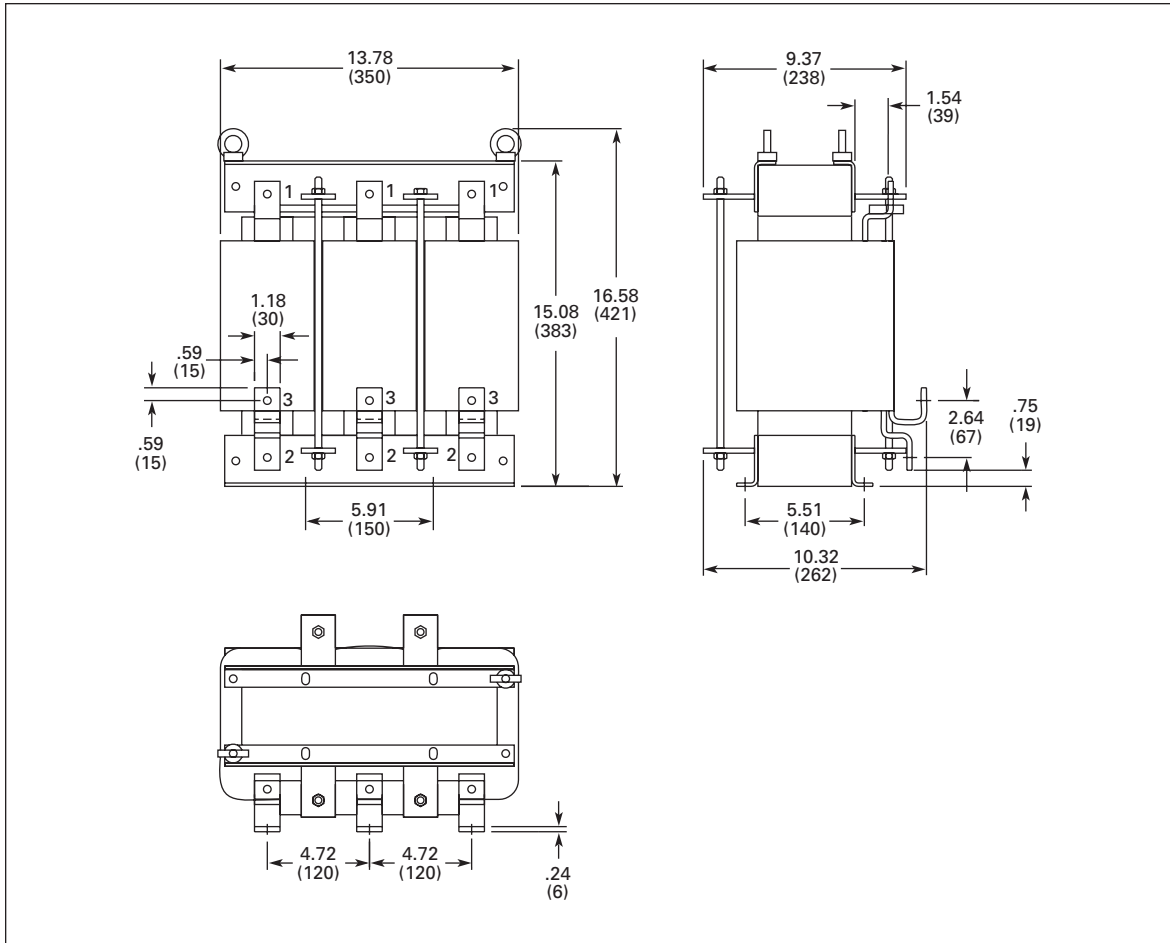

Figure A-8: AC Choke (CHK0400) Dimensions
Approximate Dimensions in Inches (mm)

April 2006

AC Choke — CHK0261

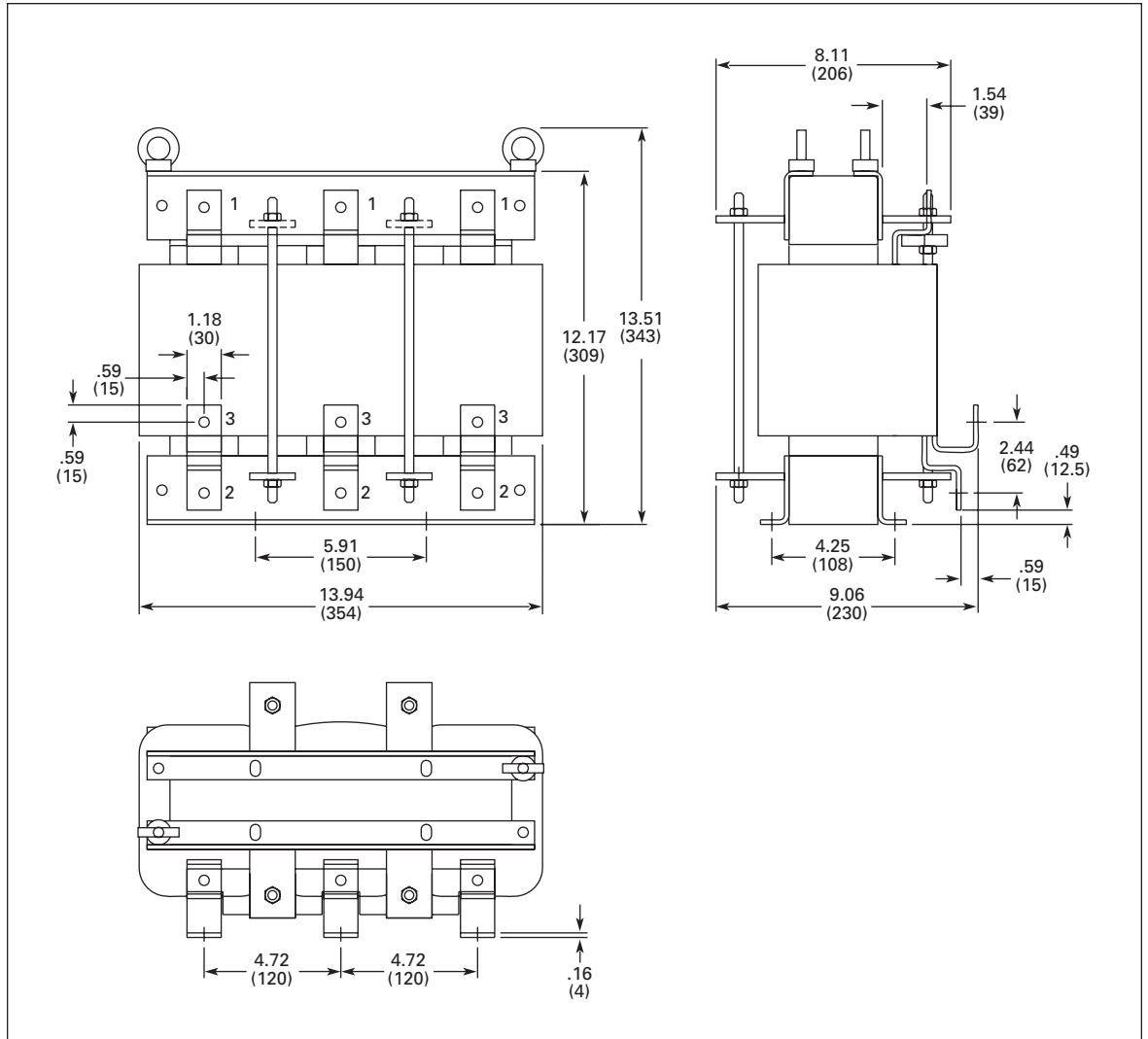

Figure A-9: AC Choke (CHK0261) Dimensions
Approximate Dimensions in Inches (mm)

Control Unit

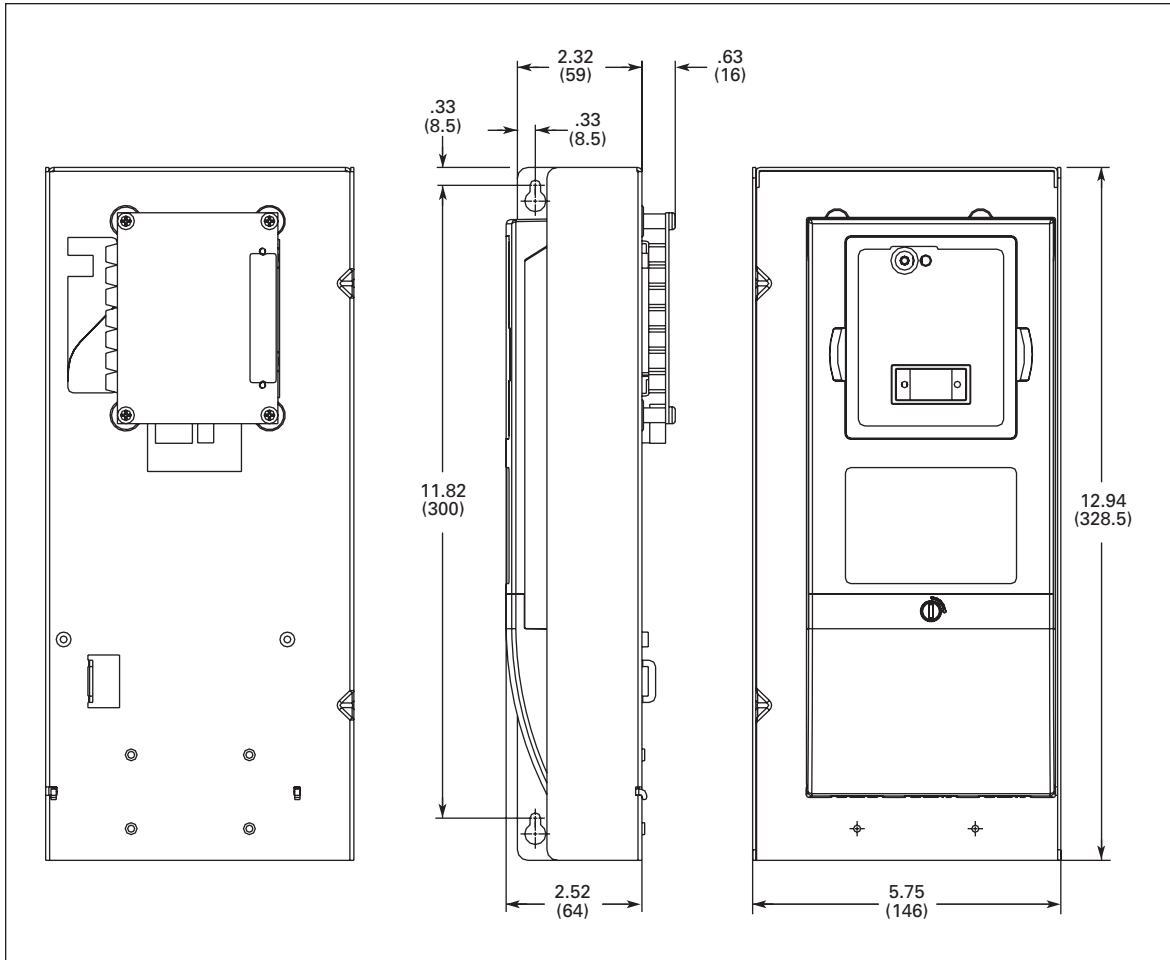

Figure A-10: Control Unit Dimensions
Approximate Dimensions in Inches (mm)

April 2006

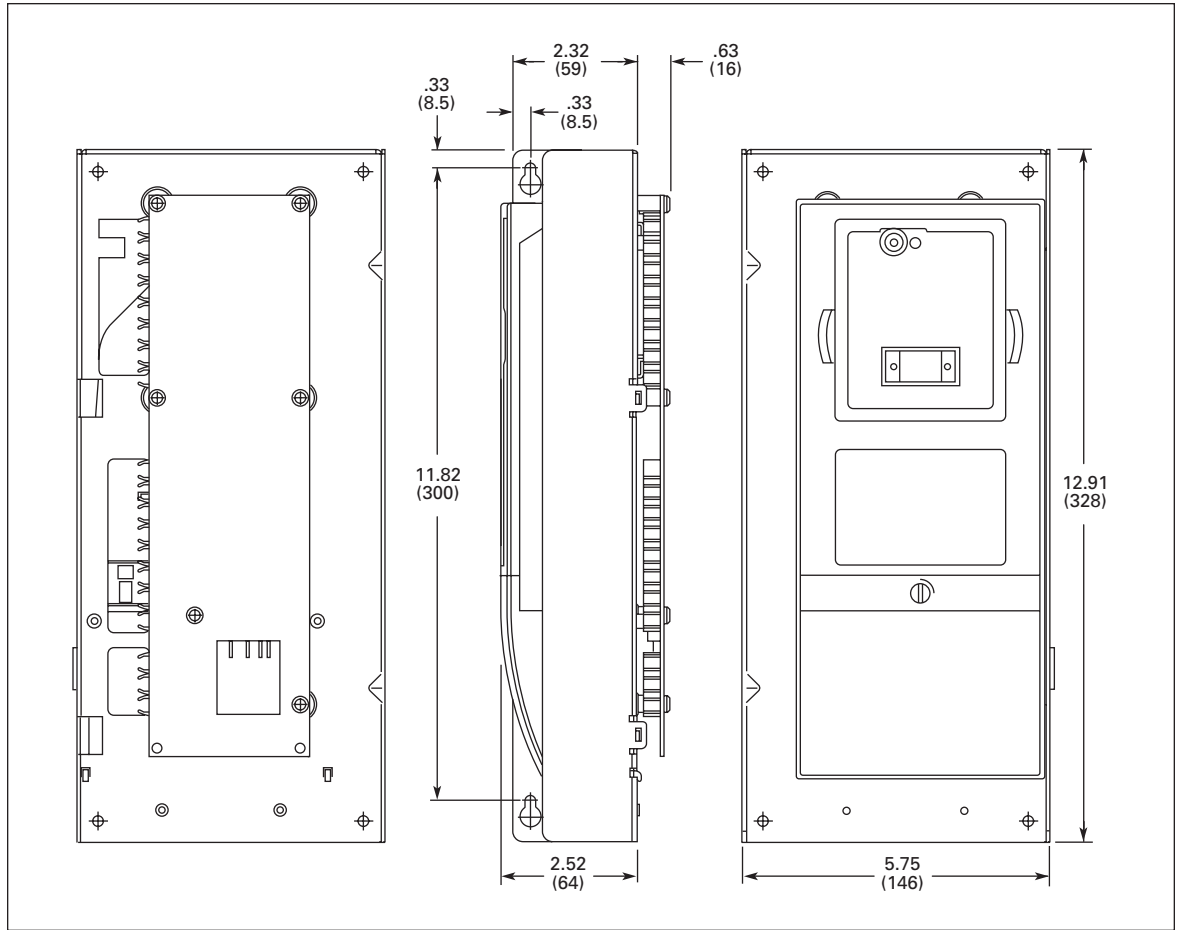

Figure A-11: Control Unit with Star-Coupler Board, FR12 or FR14 Only
Approximate Dimensions in Inches (mm)

April 2006

Appendix B — Wiring Diagrams

Optic Fiber Cables, Signal Listing and Connections

You might need to connect or re-connect the internal fiber cables if you have ordered your frequency converter frame FR10 or FR11 with the control unit separated from the power module. In frame FR12 consisting of two power modules, you will have to establish the fiber cable connections from the star coupler board to the other power module. See **Page 3-1**. Connect the cables according to **Figures B-1** and **B-2**.

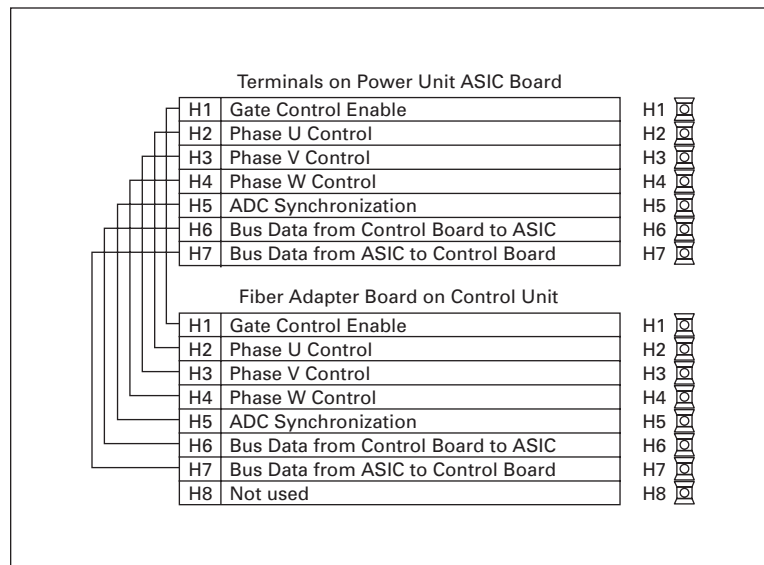

Figure B-1: Internal Fiber Cable Connections, FR10, FR11 and FR13

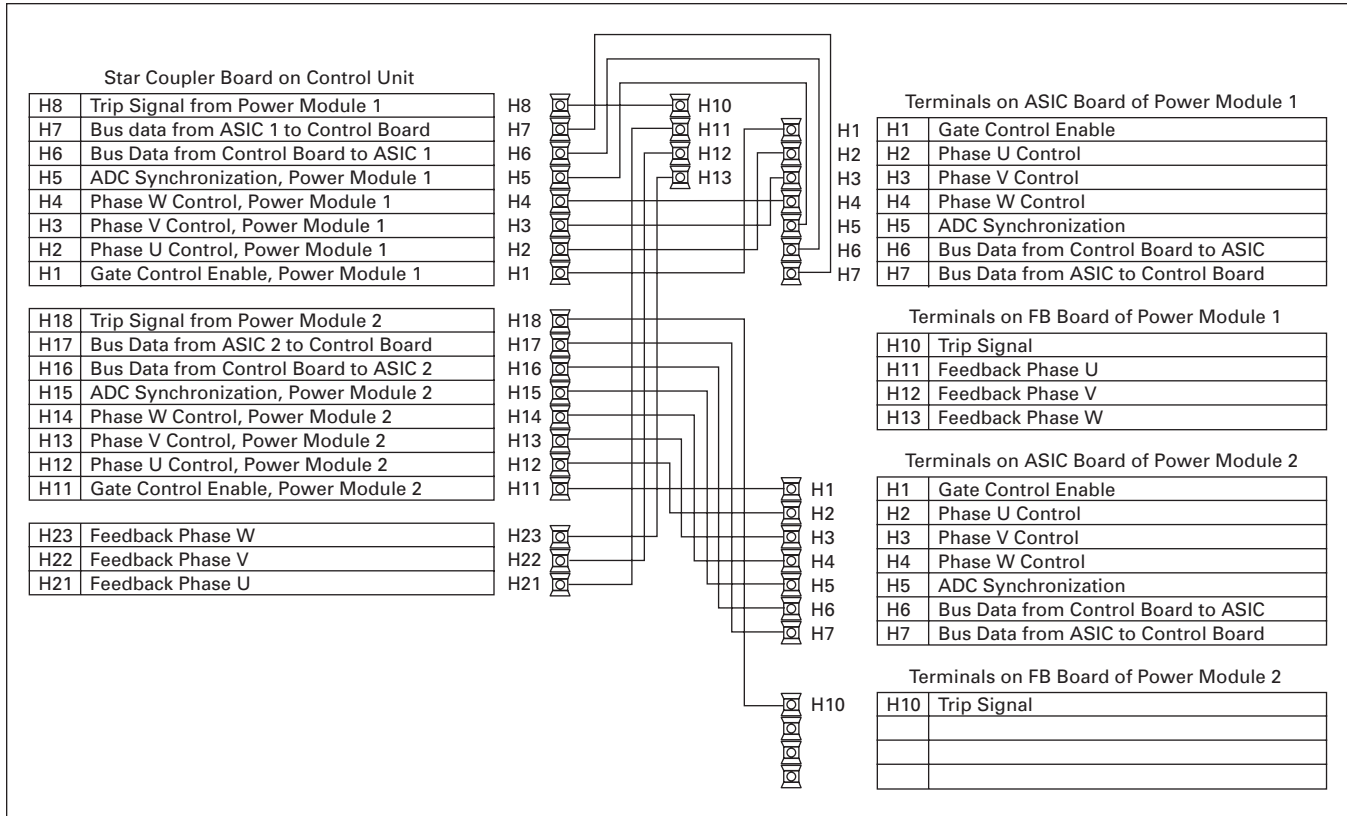

Figure B-2: Internal Fiber Cable Connections, FR12 and FR14

April 2006

Appendix C — Additional Fuse Recommendations

Table C-1: Ferraz Chawmut Fuse Recommendations

Frame	Type	Fuse Size	DIN43620	DIN43653 (80 mm)	DIN 43653 (110 mm)	Threaded End Contacts (Metric)	Fuse I _n (V)	Qty. of Fuses per Drive
Mains Voltage 380 – 500V								
FR10	0385	2	2 PV 0700	32 D08A 0700	32 D11A 0700	32 TTF 0700	700	3
FR10	0385	2	2 PV 0450	32 D08A 0450	32 D11A 0450	32 TTF 0450	450	6
FR10	0460	3	3 PV 1000	33 D08A 1000	33 D11A 1000	33 TTF 1000	1000	3
FR10	0460	2	2 PV 0450	32 D08A 0450	32 D11A 0450	32 TTF 0450	450	6
FR10	0520	3	3 PV 1000	33 D08A 1000	33 D11A 1000	33 TTF 1000	1000	3
FR10	0520	2	2 PV 0450	32 D08A 0450	32 D11A 0450	32 TTF 0450	450	6
FR11	0590	2	2 PV 0700	32 D08A 0700	32 D11A 0700	32 TTF 0700	700	6
FR11	0650	2	2 PV 0700	32 D08A 0700	32 D11A 0700	32 TTF 0700	700	6
FR11	0730	2	2 PV 0700	32 D08A 0700	32 D11A 0700	32 TTF 0700	700	6
FR12	0820	3	3 PV 1000	33 D08A 1000	33 D11A 1000	33 TTF 1000	1000	6
FR12	0920	3	3 PV 1000	33 D08A 1000	33 D11A 1000	33 TTF 1000	1000	6
FR12	1030	3	3 PV 1000	33 D08A 1000	33 D11A 1000	33 TTF 1000	1000	6
FR12 DC-link	①	2	2 PV 0700	32 D08A 0700	32 D11A 0700	32 TTF 0700	700	2
Mains Voltage 525 – 690V								
FR10	0261	2	2 PV 0700	32 D08A 0700	32 D11A 0700	32 TTF 0700	700	3
FR10	0261	2	2 PV 0450	32 D08A 0450	32 D11A 0450	32 TTF 0450	450	6
FR10	0325	2	2 PV 0700	32 D08A 0700	32 D11A 0700	32 TTF 0700	700	3
FR10	0325	2	2 PV 0450	32 D08A 0450	32 D11A 0450	32 TTF 0450	450	6
FR10	0385	2	2 PV 0700	32 D08A 0700	32 D11A 0700	32 TTF 0700	700	3
FR10	0385	2	2 PV 0450	32 D08A 0450	32 D11A 0450	32 TTF 0450	450	6
FR10	0416	3	3 PV 1000	33 D08A 1000	33 D11A 1000	33 TTF 1000	1000	3
FR10	0416	2	2 PV 0450	32 D08A 0450	32 D11A 0450	32 TTF 0450	450	6
FR11	0460	3	3 PV 1000	33 D08A 1000	33 D11A 1000	33 TTF 1000	1000	3
FR11	0460	2	2 PV 0700	32 D08A 0700	32 D11A 0700	32 TTF 0700	700	6
FR11	0502	3	3 PV 1000	33 D08A 1000	33 D11A 1000	33 TTF 1000	1000	3
FR11	0502	2	2 PV 0700	32 D08A 0700	32 D11A 0700	32 TTF 0700	700	6
FR11	0590	2	2 PV 0700	32 D08A 0700	32 D11A 0700	32 TTF 0700	700	6
FR11	0590	2	2 PV 0700	32 D08A 0700	32 D11A 0700	32 TTF 0700	700	6
FR12	0650	2	2 PV 0700	32 D08A 0700	32 D11A 0700	32 TTF 0700	700	6
FR12	0750	2	2 PV 0700	32 D08A 0700	32 D11A 0700	32 TTF 0700	700	6
FR12	0820	3	3 PV 1000	33 D08A 1000	33 D11A 1000	33 TTF 1000	1000	6
FR12 DC-link	①	2	NA	NA	12.5 URD 72D11A 0500	12.5 URD 72 TTF 0500	500 ②	2

① In FR12 12-pulse drive or if FR12 (6- or 12-pulse) has internal brake; DC-links between units are connected together. If connected together; there must be DC-link fuses in DC-minus and DC-plus poles between the units. (In 6-pulse drive without internal brake, DC-links between units are separate and there is no need for fuses.)

② Fuse Un=1000V / 1250V

Data written in shaded bold refer to 12-pulse drives (6-phase supply).

The aR fuses are thermally rated into switch fuse in 50° ambient temperature.

Company Information

Eaton's electrical business is a global leader in electrical control, power distribution, and industrial automation products and services. Through advanced product development, world-class manufacturing methods, and global engineering services and support, Eaton's electrical business provides customer-driven solutions under brand names such as Cutler-Hammer®, Powerware®, Durant®, Heinemann®, Holec® and MEM®, which globally serve the changing needs of the industrial, utility, light commercial, residential, and OEM markets. For more information, visit www.EatonElectrical.com.

Eaton Corporation is a diversified industrial manufacturer with 2005 sales of \$11.1 billion. Eaton is a global leader in electrical systems and components for power quality, distribution and control; fluid power systems and services for industrial, mobile and aircraft equipment; intelligent truck drivetrain systems for safety and fuel economy; and automotive engine air management systems, powertrain solutions and specialty controls for performance, fuel economy and safety. Eaton has 60,000 employees and sells products to customers in more than 125 countries. For more information, visit www.eaton.com.

Eaton Electrical Inc.
1000 Cherrington Parkway
Moon Township, PA 15108-4312
USA
tel: 1-800-525-2000
www.EatonElectrical.com

EAT•N

Cutler-Hammer

© 2006 Eaton Corporation
All Rights Reserved
Printed in USA
Publication No. MN04001001E/CPG
April 2006